

TRANSLATION OF
"ISTRUZIONI ORIGINALI"

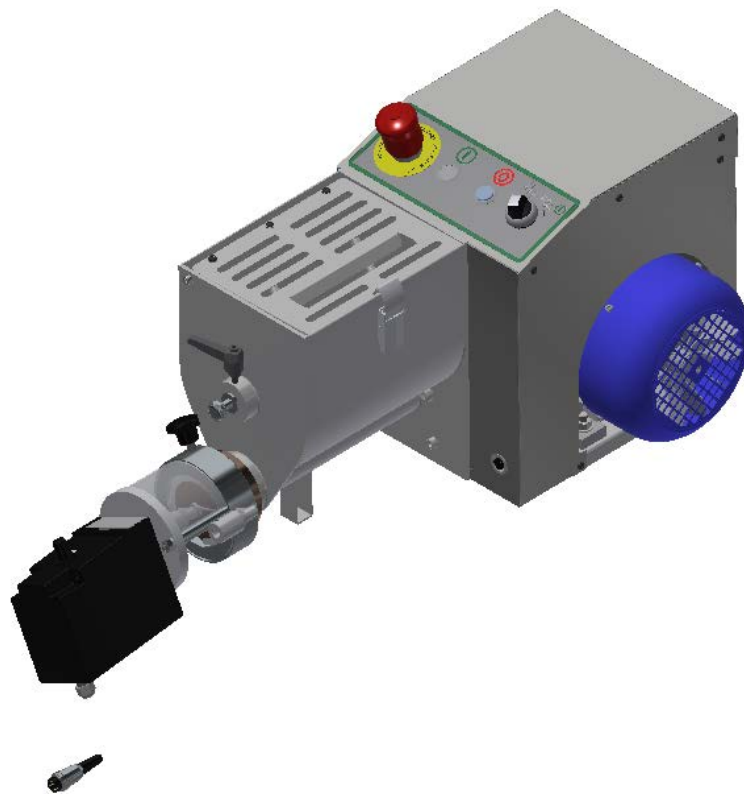

IMPERIA & MONFERRINA S.p.A.

AUTOMATIC FRESH PASTA MACHINE DOLLY



User and Maintenance Manual

Construction year: 2017
Edition: 06/2017

Revision: 04

REVISIONS

REVISIONS				
MODEL	LANGUAGE	DATE	VERSION	NOTE
DOLLY	English	03/13	01	FIRST RELEASE
DOLLY	English	11/14	02	UPDATE
DOLLY	English	04/15	03	UPDATE
DOLLY	English	6/17	04	UPDATE

The information contained in this handbook is the property of **IMPERIA & MONFERRINA S.P.A.**

Drawings and other documents that accompany the machine are property of **IMPERIA & MONFERRINA S.P.A.**

It is forbidden to distribute and/or duplicate, under any form or by any electronic or mechanical means, this handbook, even partially, without written authorization from **IMPERIA & MONFERRINA S.P.A.**

In the case of doubts or difficulty in understanding or interpreting the handbook, the original/official version indicated by "**ISTRUZIONI ORIGINALI**" on the cover, is to be considered the valid version.

We have checked with care and attention that the contents of this documentation correspond to the machine in question. However, since possible differences cannot be excluded, we cannot guarantee a perfect consistency. The contents of this documentation are periodically verified and any corrections or modifications will be included in the subsequent editions.

Some of the pictures included in this handbook must be considered as an example, therefore they may not refer to the machine here in described.

HANDBOOK STRUCTURE

The manual is divided into 8 chapters.

CHAPTER 1 – GENERAL INFORMATION

This chapter contains general descriptions regarding the handbook structure.

CHAPTER 2 – SAFETY

This chapter contains a description regarding the standards, working environment conditions, ergonomics, accident prevention devices used, residual risks, warning plates applied to the machine.

CHAPTER 3 – GENERAL DESCRIPTION

This chapter contains the description of the functioning principles, general technical data and description of mechanical, electrical and fluidic units of the machine.

CHAPTER 4 – INSTALLATION

This chapter contains the instructions for the correct installation in the user plant, the connections to the plant power mains, the checks and controls and any adjustments to be made before start-up.

CHAPTER 5 –USE

This chapter, addressed to the machine operators and maintenance technicians, contains the instructions for use of the machine with the different operating cycles, and describes the controls available for the operator, the more important operating sequences and how to use the diagnostics systems.

CHAPTER 6 – MAINTENANCE

This chapter, addressed to the maintenance technicians contains the system maintenance schedule. It contains the warnings, precautions and instructions to correctly carry out the maintenance operations on the machine

CHAPTER 7 – SPARE PARTS

CHAPTER 8 – WIRING DIAGRAM

TABLE OF CONTENTS

1.	GENERAL INFORMATION.....	1-1
1.1	INTRODUCTION.....	1-1
1.2	GLOSSARY	1-2
1.3	SYMBOLS.....	1-4
1.4	ADDRESS OF MANUFACTURER	1-5
1.5	SAFETY STANDARDS.....	1-5
1.6	RESPONSIBILITIES OF THE MANUFACTURER	1-6
1.7	MACHINE MANAGEMENT.....	1-6
1.8	WARRANTY.....	1-7
1.9	SUGGESTIONS FOR PASTA PRODUCTION.....	1-8
2.	SAFETY	2-1
2.1	GENERAL INFORMATION.....	2-1
2.2	DIRECTIVES APPLIED	2-1
2.2.1	Harmonised technical standards	2-1
2.2.2	Machine Certification	2-2
2.2.3	Foreseen and Unforeseen Uses.....	2-2
2.3	ENVIRONMENTAL WORKING CONDITIONS.....	2-3
2.3.1	Explosive Atmospheres	2-3
2.3.2	Lighting	2-3
2.3.3	Vibrations.....	2-3
2.3.4	Noise.....	2-4
2.3.5	Electromagnetic Emissions	2-4
2.4	SAFETY DEVICES APPLIED ON THE SYSTEM	2-5
2.4.1	Energy Cut-out.....	2-6
2.4.2	Fixed and Mobile Protections	2-7
2.4.3	Emergency Stop	2-8
2.4.4	Personal protection Devices	2-9
2.5	RESIDUAL RISKS	2-10
2.5.1	General information	2-10
2.5.2	Residual Risks	2-10
2.5.3	Plates Installed on Machine.....	2-11
3.	GENERAL DESCRIPTION	3-1
3.1	MACHINE MAIN COMPONENTS.....	3-1
3.2	TECHNICAL SPECIFICATIONS.....	3-2
3.3	CHARACTERISTICS OF MACHINE NEW VERSION.....	3-3
3.3.1	General characteristics	3-3
3.3.2	Description of controls	3-4
3.4	ACCESSORIES SUPPLIED	3-6
3.5	OPTIONAL ACCESSORIES.....	3-6
4.	GENERAL	4-1
4.1	INSTALLATION.....	4-1
4.1.1	Positioning	4-1
4.1.2	Installation.....	4-2
4.2	MACHINE ELECTRICAL CONNECTION.....	4-5
4.2.1	Safety microswitch check	4-6
4.3	REMOVAL AND DISPOSAL OF PACKAGING	4-7

5.	USE	5-1
5.1	WORK CYCLE	5-1
5.2	CHANGING THE PLATE	5-4
6.	MAINTENANCE	6-1
6.1	GENERAL SAFETY PRECAUTIONS	6-1
6.1.1	General Hazard Notes	6-2
6.1.2	General Warnings	6-3
6.2	QUALIFICATION OF MAINTENANCE TECHNICIANS.....	6-4
6.2.1	General Tasks.....	6-4
6.2.2	Tasks of Qualified Operators	6-5
6.2.2.1	<i>Machine manager</i>	6-5
6.3	SAFETY CONTROL PLAN	6-6
6.3.1	Checks and Functional Tests on Safety Devices	6-6
6.4	STOP PROCEDURE FOR MAINTENANCE	6-7
6.5	CLEANING AND MAINTENANCE	6-8
7.	SPARE PARTS	7-1
7.1	COMPONENTS SUBJECT TO WEAR AND MECHANICAL FATIGUE	7-1
7.2	LIST OF RECOMMENDED SPARE PARTS	7-1
7.2.1	Table 1	7-2
7.2.2	Table 2	7-3
7.2.3	Table 3	7-5
7.2.4	Table 4	7-7
7.2.5	Table 5	7-9
7.2.6	LM90920 dough-cutter motor	7-11
8.	SINGLE-PHASE WIRING DIAGRAM 220-240V E 110-120V	8-3

GENERAL INFORMATION	1
SAFETY	2
GENERAL DESCRIPTION	3
INSTALLATION	4
USE	5
MAINTENANCE	6
SPARE PARTS	7
SINGLE-PHASE WIRING DIAGRAM	8

DOLLY

IMPERIA & MONFERRINA S.p.A.

BLANK PAGE

1. GENERAL INFORMATION

1.1 INTRODUCTION



NOTE

IMPERIA & MONFERRINA S.P.A. the machine manufacturing company, is indicated in the handbook with the name: **Manufacturer**.



NOTE

The Company purchasing the machine, is indicated in the handbook with the name: **Customer**.

The Manufacturer recommends a training course for the persons assigned to the running of the machine to assure perfect familiarity and knowledge of the procedures.

This manual contains the features, performances, instructions for use and the references to the preventive and remedial operations of the machine.

The Manufacturer insists that this document is read by the persons assigned to the running and maintenance of the machine, as well as by the persons who carry out the transport and assembly.

This document is the instructions handbook for the:

AUTOMATIC FRESH PASTA MACHINE “DOLLY”

and has been drawn up in compliance with Directive 2006/42/EC.

The Use and Maintenance Handbook is to be considered an integral part of the machine, and is to be kept until final dismantling. It is to be kept by the person in charge of the machining service after the final installation.

1.2 GLOSSARY

Control circuit (of a machine): circuit used to control the machine operation and to protect the power circuits.

Component: part of the electrical equipment, usually specified by its function, but used in various applications.

Machines Directive: DIRECTIVE 2006/42/EC OF THE EUROPEAN PARLIAMENT AND COUNCIL concerning the harmonising of the laws of Member States related to machinery.

Device: unit of an electrical system that transmits but does not use electric power

Control device: device inserted in a control circuit and used to control machine functioning (e.g.. position sensors, manual control switches, relays, electromagnetically controlled valves).

Bill of Materials : list of components that are part of mechanical units, fluidic or electrical system, indicated with the quantity, code and name of supplier.

Supplier: body (for example, manufacturer, installation dealer, systems integrator) that supplies the equipment or services associated to the machine (the user can also act as manufacturer for himself).

Machine: a group of parts or components, at least one of which is moving, connected together and possibly with drives, with control and power circuits, etc., integrally connected for a precise application, indicated for conversion, treatment, movement and conditioning of a material. Interchangeable equipment that changes the function of a machine, procured on the market to be mounted by the operator onto a machine or a series of different machines or on a tractor, within the limits in which this equipment is not a spare part or a tool.

Marking: symbol and wording to identify the machine, applied by the manufacturer. (Chapter III - Article 10 directive 2006/42/EC).

Safe operating procedure : a working method that reduces risks.

Obstacle: an element intended to prevent direct accidental contact, but that does not impede a direct intentional contact (Item 3.38 of European Standard EN 60204-1).

Operator: person qualified to install, run, adjust, clean and carry out maintenance on the machine. (Annex I - 1.1.1 directive 2006/42/CE).

Danger /Hazard: Potential source of damage. (Chapter 3.6 of the European Standard EN ISO 12100).

Exposed person: person who is entirely or partially in a hazardous zone.

Safe operating procedure: a working method that reduces risks.

Safety protections: guard or protection device used as a safety measure to protect the persons against hazards that are present or potential.

Protections (protection criteria): means of protection that uses measures to protect persons against hazards that cannot be rationally eliminated, against risks that cannot be sufficiently reduced by protection measures integrated in the design. (Chapter 3.20 of European Standard EN ISO 12100).

Reference person: person responsible for certain operations or assessments that could arise during operation or maintenance.

Risk: combination of probabilities that a damage occurs and the severity of that damage. (Item 3.12 of Standard EN ISO 12100).

Transport: operations involved to transfer the machine from the manufacturer's assembly site to the final workplace of the Customer.

Incorrect use: machine use out of the limits specified in the technical documentation.

User: those who use the machine and associated electrical equipment.







NOTE

The terminology has been taken from the European Standards listed in chapter 2 "SAFETY".

1.3 SYMBOLS

Some symbols are used in the handbook to call the attention of the reader and to highlight certain aspects which are especially important.

SYMBOL	MEANING	NOTES
	DANGER	Indicates a hazard with accident risk, even death, for the user. Pay very careful attention to the texts indicated by this symbol
	WARNING	A warning of possible deterioration or damage to the machine, equipment or personal belongings of the user. Pay attention to the texts indicated by this symbol.
	CAUTION NOTE	A warning or note regarding key functions or useful information. Pay attention to the texts indicated by this symbol.
	ADDITIONAL INFORMATION	Texts that contain additional information are indicated by this symbol. This information does not relate directly to the description of an operation or to the development of a procedure. It may give reference to other supplementary documentation or to other sections of the handbook.

1.4 ADDRESS OF MANUFACTURER

For any type of information or clarification regarding the use, maintenance, installation etc, the Manufacturer Technical Office is always available for requests from the Customer.

Please state your requests in clear terms, with reference to this handbook, and always indicating the data of the machine identification plate.

Requests for interventions, technical assistance in the Customer's works, or explanations regarding technical aspects of this document, are to be addressed to:

IMPERIA & MONFERRINA S.p.A.

Via Statale, 27/A - 14033 – Castell'Alfero (AT) - Italia

Tel: 0039.0141.27.60.11

www.imperiamonferrina.com

1.5 SAFETY STANDARDS

The specifications, indications, standards and related safety notes described in the various chapters of the handbook have the purpose of defining a series of actions and obligations to be observed when carrying out the different activities that form the modes of use foreseen for the machining centre, so as to operate under safe conditions for the workers, the equipment and the surrounding environment. The safety rules included are directed to all the persons authorised, instructed and assigned to carry out the operations regarding:

- Transport
- Installation
- Functioning
- Use
- Management
- Maintenance
- Cleaning
- Putting Out of Service And Dismantling

1.6 RESPONSIBILITIES OF THE MANUFACTURER

The Manufacturer shall not be held in any way liable for incidents caused by incorrect or improper use of the machining centre, or for any damage cause by the use of spare parts that are not those specified, by maintenance operations not carried out correctly and/or by tampering on system circuits, components and software.

The responsibility to ensure the application of the safety precautions is that of the technician in charge of the activities to be carried out on the machine. The Customer is to ensure that the operators authorised to carry out the required activities are qualified, that they observe and are fully aware of the provisions contained in this document and the general safety standards applied to the machine.

Non-observance of safety standards can cause injuries to the personnel and damage to the equipment.

1.7 MACHINE MANAGEMENT

The machine management is only permitted to the authorised operators who have been appropriately instructed, or who have sufficient technical experience.

The operators assigned to the running and maintenance of the system are to be aware that the knowledge and application of safety standards is an integral part of their job.

Operators not authorised to work on the machine are not to have access to the operating area and/or the control panels.

Never remove, even partially safety protections and devices installed to safeguard the persons in the machine hazardous zones.

The same rule is applied to the warning plates.

Safety protection and devices are to be kept in perfect working order, to ensure correct functioning. In the case of malfunctioning or failure on these devices, they are to be immediately repaired or replaced.

1.8 WARRANTY

The manufacturer guarantees, for a period of 12 months from the date of purchase, all parts excluding those subject to normal wear.

The warranty shall no longer be valid if the machine has been repaired by unauthorised third parties or if fixtures, accessories are used that have not been supplied by the manufacturer or have not been recommended or approved by the same, or if the serial number is altered or removed during the warranty period.

The warranty starts from the date of purchase, indicated on the official document at the time of the machine delivery by the dealer.

The manufacturer undertakes to repair or replace free of charge those parts that within the warranty period are found to have manufacturing defects. The warranty does not cover any cleaning of functioning components.

Defects that cannot be clearly attributed to the material or the manufacture shall be examined by the Technical Assistance Centre in the works of the manufacturer.

If the claim should result unjustified, all the costs for the repair and/or replacement shall be debited to the purchaser.

The warranty certificate and the official document shall be assigned to the technical staff that carry out the repair, or who have to accompany the shipped machine for the repair.

The warranty shall not be extended following technical intervention on the machine.

The repair shall be carried out by the Technical Assistance Centre in the works of the manufacturer, and is to arrive in free port (with transport costs covered by the user, unless otherwise agreed).

In any case the following are excluded from the warranty: accidental damage caused by transport, neglect or inadequate treatment, from improper use that does not conform with the warnings indicated in the instructions handbook, and in any case factors that do not arise from normal functioning or use of the machine.

The manufacturer shall not be held in any way liable for any damage to persons or materials caused by wrong or incorrect use of the machine.

1.9 SUGGESTIONS FOR PASTA PRODUCTION

Any type of flour or durum flour or flour/durum flour mixture can be used for the dough.

The dough must be kneaded with eggs alone or an eggs/water mix.

The water can be replaced in part by finely-chopped spinach or vegetables to obtain green pastas or tomato puree to obtain red pastas or other ingredients: in these cases, it is advisable to use hard grain durum flour.

For good dough, around 300 ÷ 350 gr. of liquid is required for every kilogram of flour.

This liquid may consist of eggs alone, just water or an egg/water mixture. Since the moistness of the flour varies according to type, climate and where it is stored, the amounts indicated must be adapted to the type of flour being worked by adding or decreasing the quantity of liquid slightly.

The dough is just right when, at the end of kneading, it is in the form of grains the size of coffee beans. If the dough coalesces into an even mass, it means that too much liquid has been poured in. In this case, before extruding the dough, add a little more flour and let it mix for a bit longer.

If, however, the dough does not form little balls but remains very floury, add a little more liquid.

Here below we give a few recipes for different types of dough.

Remember that ingredients can at all times be modified and quantities changed according to your experience and taste.

Preparation of dough for mixed flour:

Fine flour 70%

Hard grain durum flour 30%

5 eggs per Kg of dough + water

Or

Hard grain durum flour 100%

5 eggs per Kg of durum flour + water

Knead for around 15 minutes with around 33% moisture.

Preparation of durum flour pasta:

(e.g. rigatoni, fusilli, conchiglie, spaghetti, etc.).

For this type of pasta only hard-grain durum flour with 30 ÷ 33% water is used.

When different types of flour are used it is a good idea to mix them well before adding liquid.

To take account of the customer's taste, salt in the rough measure of 2 gr. per Kg of flour can be added to the dough, taking care to dilute it well in water.

GENERAL INFORMATION	1
SAFETY	2
GENERAL DESCRIPTION	3
INSTALLATION	4
USE	5
MAINTENANCE	6
SPARE PARTS	7
SINGLE-PHASE WIRING DIAGRAM	8

DOLLY

IMPERIA & MONFERRINA S.p.A.

BLANK PAGE

2. SAFETY

2.1 GENERAL INFORMATION

The Customer shall instruct the personnel regarding accident risks, safety devices installed on the machine and the general rules concerning accident prevention specified by the EU Directives and the laws of the country where the machining centre is installed.

The operators are to know the position and functioning of all the machine controls and the relevant characteristics. Furthermore they are to have read and fully understood the contents of this handbook.

Maintenance operations are to be carried out by qualified operators and only after setting the machine in maintenance status.

Unauthorized tampering or replacement of one or more machine components, use of accessories that change the use of the same and the use of spare parts that are different to those recommended could cause accident risks



DANGER

It is strictly forbidden to cut out/tamper with the safety devices on the machine.
The Manufacturer declines any responsibility concerning the machine safety if this prohibition is ignored.

2.2 DIRECTIVES APPLIED

The following directives are applied to the machine described in this handbook:

- **2006/42/EC** Machines Directive
- **2004/108/EC** Electromagnetic Compatibility Directive
- **2006/95/EC** Low Voltage Directive
- **2002/95/CE** Directive concerning the use of certain harmful products in electrical or electronic equipment
- **Regulation (EC) n. 1935/2004** concerning materials and items that shall come into contact with foodstuff products.

2.2.1 Harmonised technical standards

The machine has been designed and tested in conformity with the “essential health and safety requirements” of annex 1 of European directive 2006/42/EC.

The standards used as reference for the design, realisation and inspection of the machine are listed in the technical folder archived in IMPERIA & MONFERRINA S.p.A.

2.2.2 Machine Certification

The machine is supplied with the **EC** Declaration of Conformity to the essential safety requirements as per Machines Directive 2006/42/EC (annex II A), the Low Voltage Directive 2006/95/EC and the Electromagnetic Compatibility Directive 2004/108/EC.



NOTE

Any modification made to the Machining centre will immediately annul the **EC** certification issued by the Manufacturer.

Imperia & Monferrina S.p.A.					
Via Vittime di Piazza Fontana 48 - 10024 Moncalieri (TO) ITALY					
Tel. +39 0141 27.60.11					
MODEL		CE			
S/N					
YEAR	KW	VOLT	PHASE	Hz	Kg

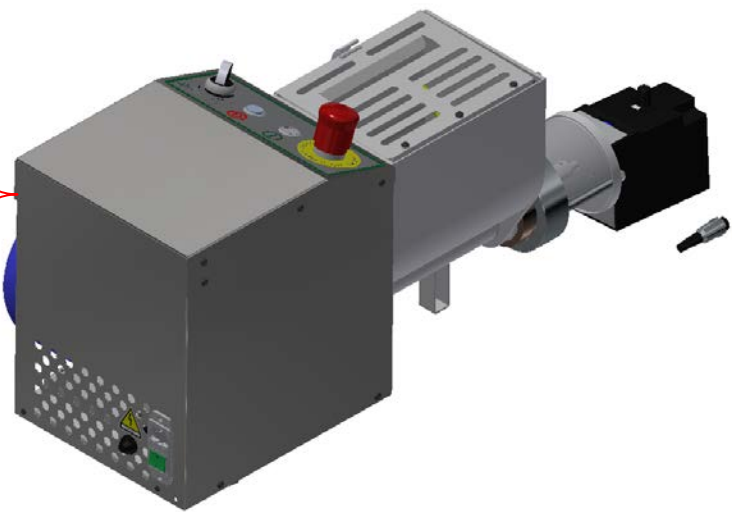

2.2.3 Foreseen and Unforeseen Uses

The machine has been designed, built and outfitted exclusively for the production of drawn pasta, obtained from raw materials such as durum wheat flour or bread wheat flour with the addition of water and/or eggs.

The pasta extruders, to obtain the different shapes, may be of two types, in bronze or in Teflon.

The pasta obtained with bronze extruders has a rougher and more opaque surface.

With Teflon extruders, the pasta is smoother and with a more glossy surface. These extruders are more delicate than those in bronze and the hourly pasta production output is slightly higher.

A different use to that specified shall be considered improper use. In any case, the machine has been designed for professional industrial use.

2.3 ENVIRONMENTAL WORKING CONDITIONS

To permit the best possible environment conditions, it is necessary that the Customer organizes the machine and related systems in the workshop in a manner that provides good ventilation.

The machine is to be installed in an environment equipped with all the safety precautions required by the laws in force in the user country.

The environment temperature range is to be between 20°C and 40°C.

2.3.1 Explosive Atmospheres

The machine has not been designed and constructed to operate in explosive, or partially explosive atmospheres.



DANGER

In the case of fire, always immediately cut out the power from the main switch of the main electric cabinet.

It is not sufficient to use the emergency pushbuttons, because these do not cut-out the main power of the cabinets/panels.

2.3.2 Lighting

The machine is not fitted with an autonomous lighting system.

2.3.3 Vibrations

The machine does not produce vibrations that are hazardous for the persons operating on it.



WARNING

Excessive vibration can only be caused by a mechanical failure, that is to be immediately notified and removed, to avoid jeopardising the safety of the machine and those who operate on it.

2.3.4 Noise

The noise has been measured in accordance with the requirements of acoustic standard EN ISO 11200 and related standards.

The typical phonometrical data is kept by the Manufacturer.

The machine operating characteristics are such that, in a dry run, overall noise generated is less than 75 dB (A), measured in the operator workstations.



NOTE

The sound pressure level under actual working conditions will depend on the characteristics, programming of the specific processes and the materials used.



NOTE

Measurement of the noise level to which the operators are exposed is to be carried out by the user, in accordance with the requirements of the laws in force in the relevant country.

2.3.5 Electromagnetic Emissions

The machine contains electronic components subject to the Electromagnetic Compatibility standards, subjected to conducted and radiated emissions.

The emission values are kept in compliance with the standard by means of components installed in accordance with the Electromagnetic Compatibility directive, appropriate connections and the installation of filters where necessary.

Therefore the machining centre is in conformity with the Electromagnetic Compatibility Directive (EMC).



WARNING

Any maintenance activities on electrical equipment carried out in a manner that does not conform, or wrong replacement of components, could jeopardise the efficiency of the equipment.

2.4 SAFETY DEVICES APPLIED ON THE SYSTEM

The machine is equipped with safety devices/solutions:

Type of device/solution	Function
Main switch	To cut-out machine electric power
Fixed and mobile protections	Enclosure of machine hazardous zones
Emergency stop	Emergency stop of entire system, or part of the same.
Personal protection devices	Protections for the operator when carrying out the jobs



ADDITIONAL INFORMATION

For information regarding the safety devices installed on the machine, see the specific handbooks.

2.4.1 Energy Cut-out

Function: To cut-out power supplies of the machine

Characteristics and method: Before starting any type of maintenance job on the system, or part of the same, cut-out the power supplies and discharge any accumulated energy.

Cut-out the machine electrical supply acting on the main switch.

After cutting out the power supplies, padlock the cut-out levers.



WARNING

For maintenance work, it is not sufficient to press the emergency pushbuttons to cut out the machine power supplies.

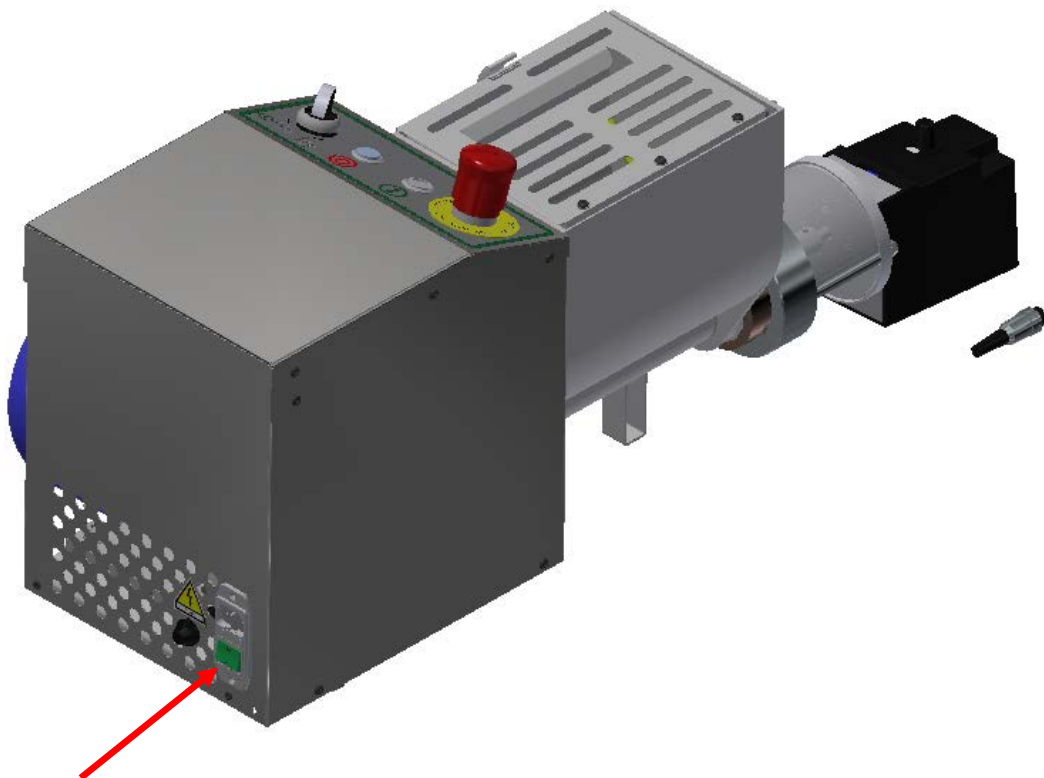

2.4.2 Fixed and Mobile Protections

Function: To segregate hazardous zone of the machine

Characteristics and method: Protections are fixed and mobile.

Fixed protections:

The purpose of the fixed protections is to prevent access to machine component movements during the operating cycle.

The guards (casings) that cover/protect moving parts are secured to the structure with screws that require a special tool to remove them.

The fixed protections and casings are not controlled and the removal is exclusively subordinated to maintenance operations with the machine power supplies deactivated.

Mobile protections:

The machine is fitted with a safety cover (1) with a safety hook (2) that stops the processing if the cover is lifted.



WARNING

For maintenance it is not sufficient to open the access door to cut out the system power supplies. The Manufacturer shall not be held liable if the machine is put into function with guards that are incomplete, open and/or not installed.

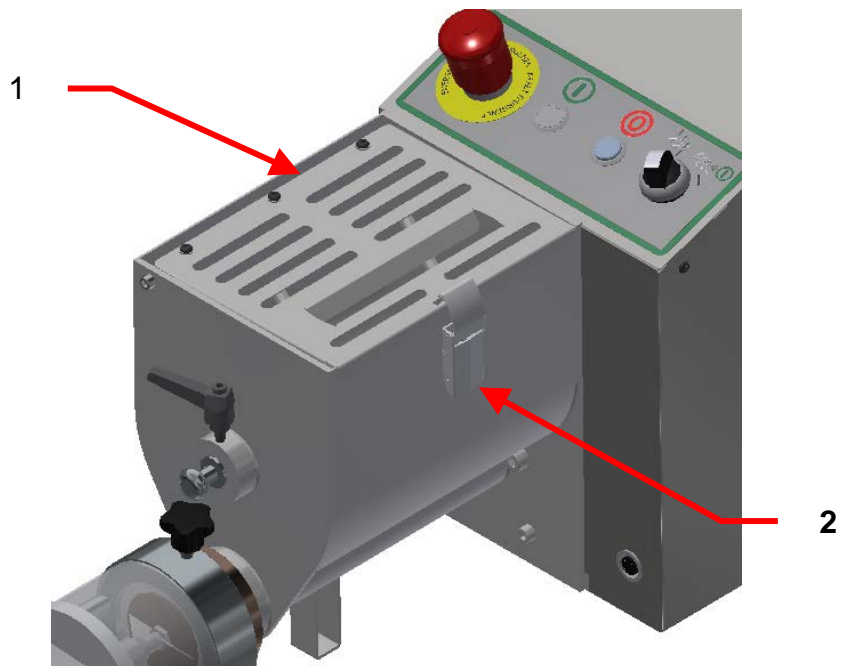

2.4.3 Emergency Stop

Function: Emergency stop by pressing the red head emergency push-button on the machine, following a hazard risk for the safety of the operators and/or the system.

Characteristics and method: All automatic motion of the system is stopped.

Pressing this push-button deactivates all movements, due to cut-out of power to PLC outputs that control all movements of all the machine actuators.

If pressed, the emergency push-button remains in low position. To reset, turn the control emergency push-button clockwise.



WARNING

For maintenance work, it is not sufficient to press the emergency push-buttons to cut out the machine power supplies.



WARNING

Check the emergency push-buttons periodically to ensure correct functioning.

Emergency stop

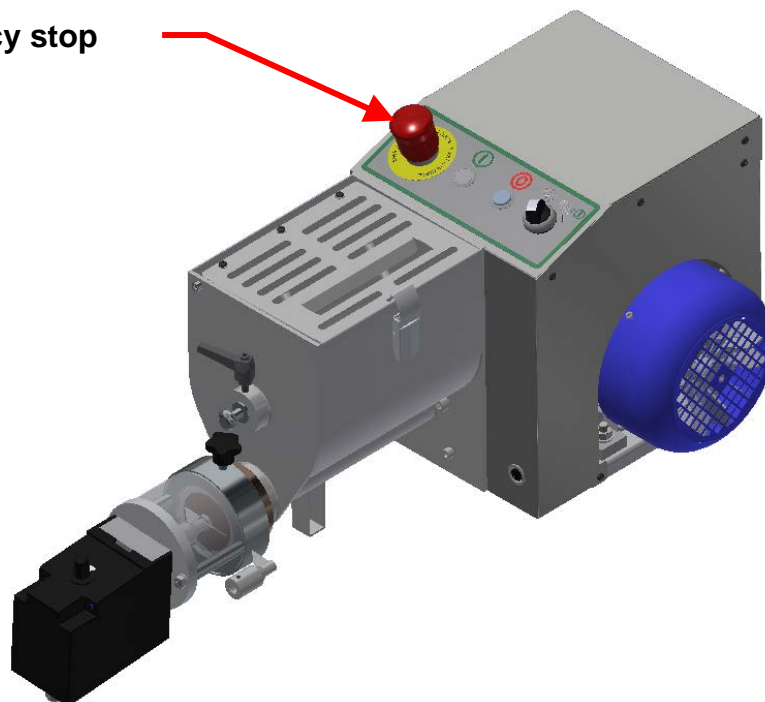

2.4.4 Personal protection Devices

Function: To protect the operator when working.

Characteristics and method: The persons operating on the machine are to use personal protection devices to cut the possibility of risks to a minimum.



DANGER

Clothing of those who operate or carry out maintenance on the machine, is to conform to the essential safety requirements and the laws in force in the country where the machine is installed.



WARNING

During handling and maintenance operations, the workers are to wear appropriate work clothes to avoid accidents.

To avoid mechanical risks, such as dragging, entrapment or other, never wear bracelets, wristwatches, rings or chains during the work cycle and maintenance operations

2.5 RESIDUAL RISKS

2.5.1 General information

During the design, all the zones or parts with risks have been assessed, and as a consequence all the necessary precautions have been taken to avoid risks to persons and damage to machine components.

In order to assure the health and safety of exposed persons, at a general level the system is fitted with fixed and mobile protections, casings to cover moving parts. Furthermore, the operators running the machinery are to use the specific personal protection devices.



NOTE

Periodically check the functioning of all safety devices.
Do not remove the fixed and mobile protections installed on the machine.
Do not introduce unnecessary objects and tools in the system working area.

2.5.2 Residual Risks

After carefully considering all possible system risks, all the necessary solutions have been applied to eliminate the risks and limit hazards for the exposed persons. However, although the system is fitted with these safety systems, some risks remain that can be eliminated or reduced by taking the relevant precautions.



WARNING

As a precautionary measure for safety, periodically check correct functioning of safety devices and the documentation supplied by the manufacturer.



WARNING

It is strictly forbidden to make any type of mechanical, electrical or fluidic modification, to avoid creating additional hazards and risks that have not been foreseen.

A list follows of the machine residual risks.

Serious injury risk



DANGER

Never start the machine with fixed and/or mobile guards removed, or not correctly assembled with the specific screws or with guard closed safety device by-passed by tampering.
Never start the machine with safety guards open and safety.

Jamming and machine stop risks



DANGER

Never leave rags, wrenches, tools, screws used for a maintenance job inside the machine.
Before starting the cycle, always carefully check and if necessary remove any foreign objects found inside.

2.5.3 Plates Installed on Machine

The Manufacturer has installed several hazard warning and obligatory plates on the machine, in accordance with standards regarding the graphic symbols to be used on systems (Directive 92/58/EC).

Maintenance shall immediately replace any plates that, due to wear, become illegible.

These plates are located in positions well in sight.



WARNING

It is strictly forbidden to remove the warning plates affixed on the machine.
The Manufacturer shall not be held in any way responsible for the machining centre safety if this prohibition is ignored.



ADDITIONAL INFORMATION

For further information regarding the warning plates installed on incorporated machine parts, see the specific handbooks.

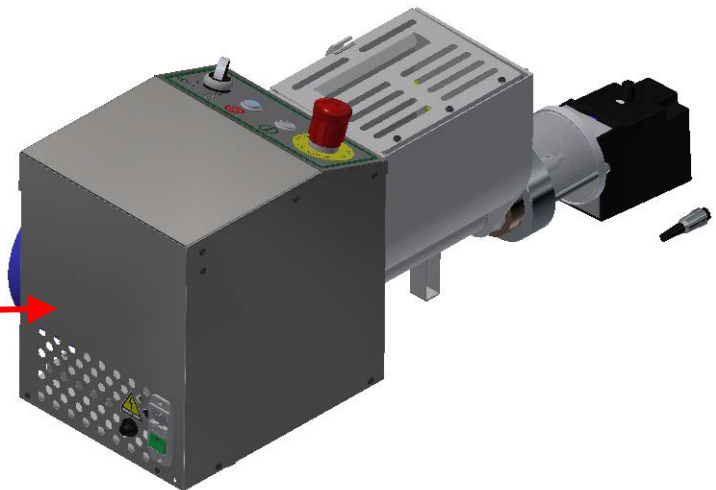

BLANK PAGE

GENERAL INFORMATION	1
SAFETY	2
GENERAL DESCRIPTION	3
INSTALLATION	4
USE	5
MAINTENANCE	6
SPARE PARTS	7
SINGLE-PHASE WIRING DIAGRAM	8

DOLLY

IMPERIA & MONFERRINA S.p.A.

BLANK PAGE

3. GENERAL DESCRIPTION

3.1 MACHINE MAIN COMPONENTS

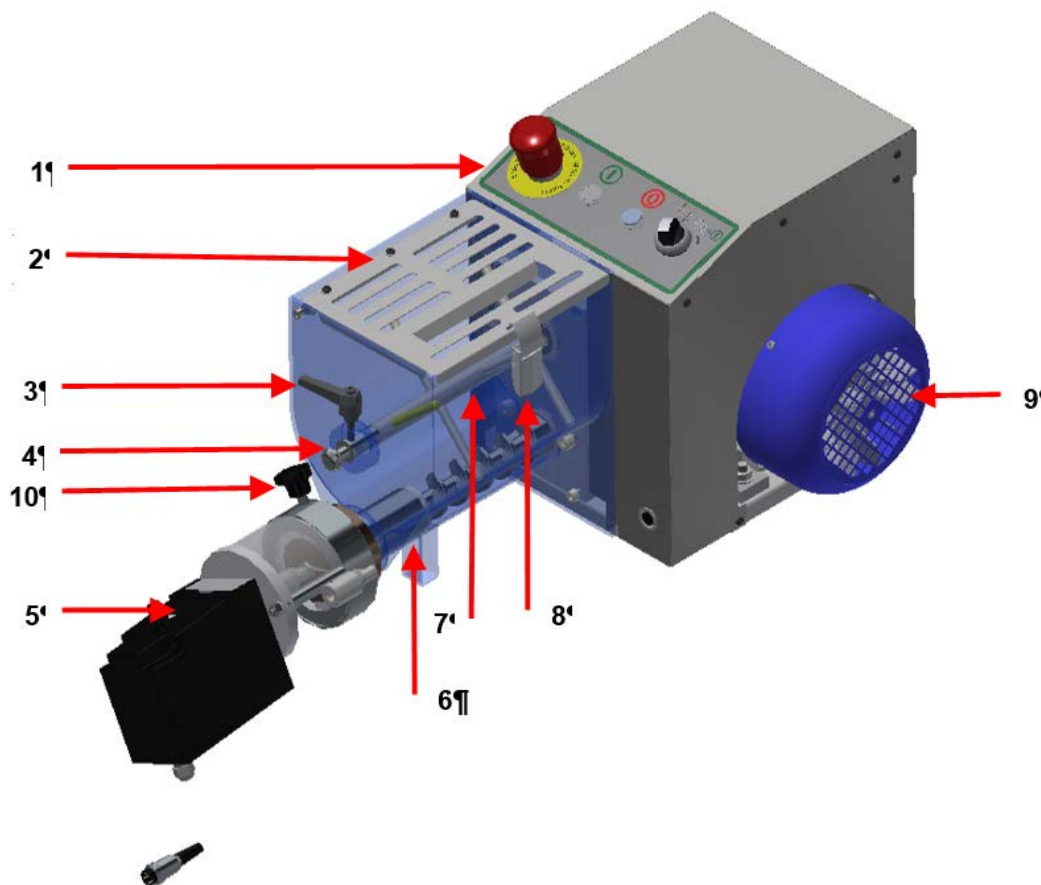

Legend:

1	Control panel
2	Safety cover
3	Mixer shaft clamp/release lever
4	Kneading shaft support pin
5	Dough-cutter motor
6	Feeder
7	Mixer shaft
8	Safety hook
9	Electric motor
10	Dough-cutter motor clamp/release knob

3.2 TECHNICAL SPECIFICATIONS

The following table contains the machine technical data.

General	
Mixing tank capacity	2 Kg
Dough production	6 ÷ 8Kg/h
Three-phase or single-phase motor	0,75 Hp
Weight	27 Kg

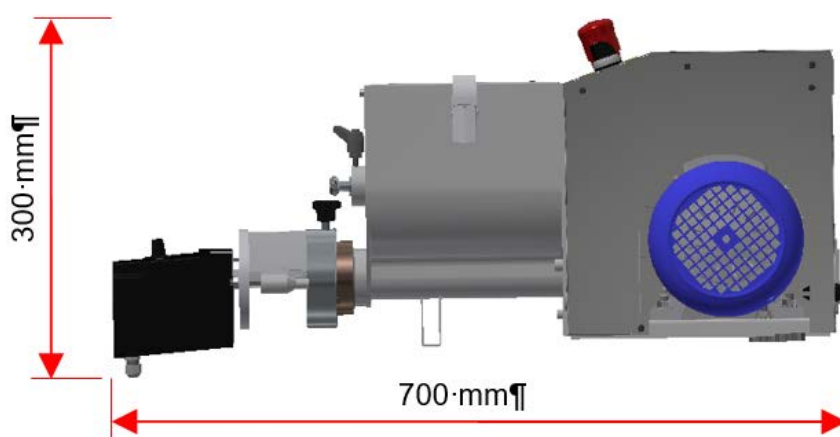

3.3 CHARACTERISTICS OF MACHINE NEW VERSION

3.3.1 General characteristics

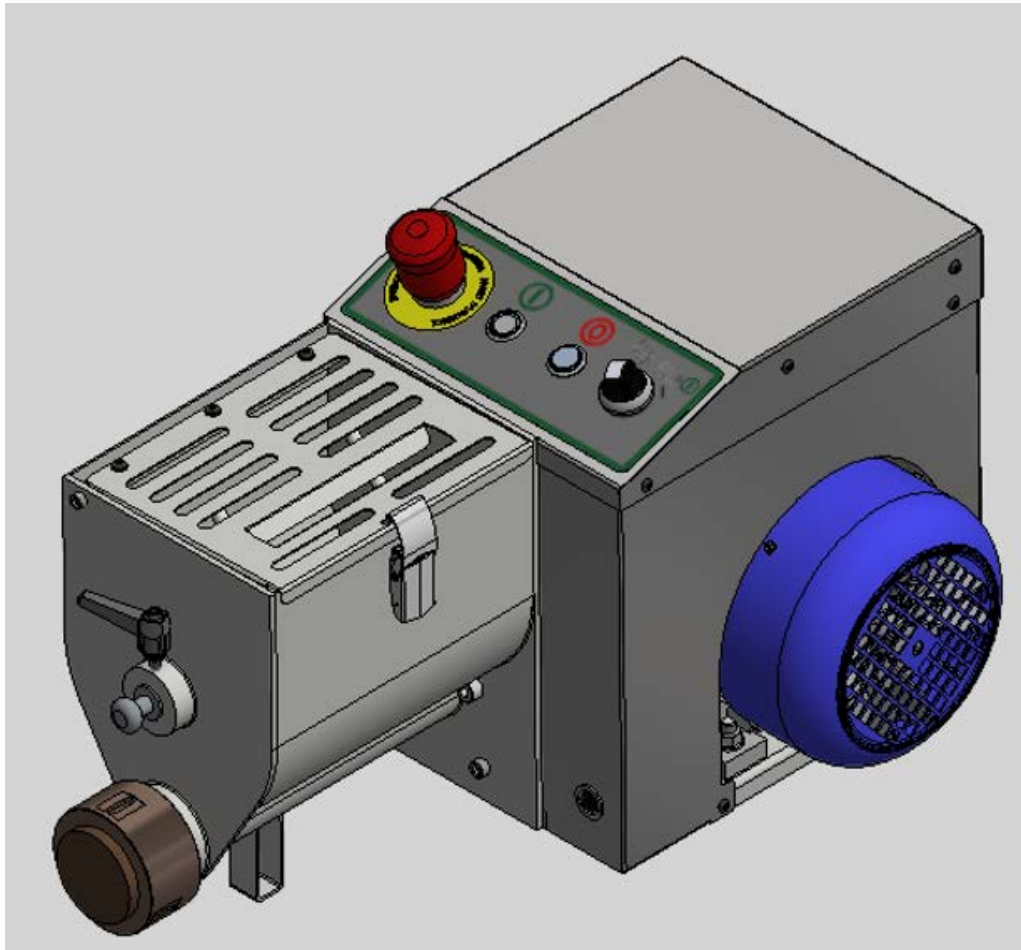

- **Control panel:** the inclination has been changed for easier visibility and better practical use. Coloured symbols have been stencilled for easier identification of the controls and vandal resistant stainless steel buttons have been inserted.
- **Two types of single-phase power supply** have been applied: the machine is on sale in two single-phase versions: 110/120V and 220/240V 50/60Hz to cover 90% of world power voltages.
- **Better motor performance:** the machine has an inverter board to be able to use a three-phase motor with the relevant advantages.
- **Main switch:** the machine has a main switch with fuse-holder on the power supply to protect internal components and an IEC connector to permit the customer to find in every part of the world the cable with the plug that he uses.
- **Motor protection:** the electronic board on the machine has a safety threshold that protects the motor and mechanical components against excessive and anomalous force on the motor caused by incorrect operations by the operator.

3.3.2 Description of controls

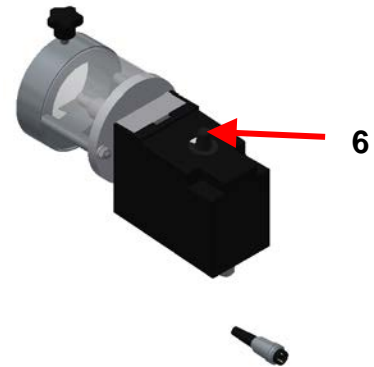
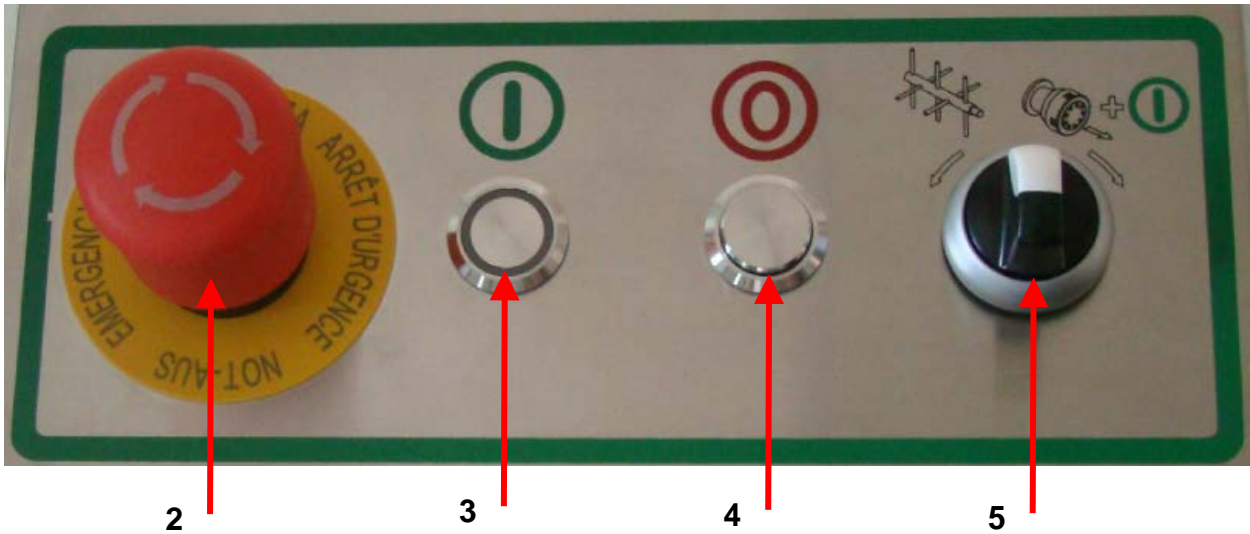

Legend:

- | | |
|---|--|
| 1 | Main switch integrated to protect electrical and electronic components; with IEC C14 connector to install the required power supply cable |
| 2 | Mushroom head emergency button |
| 3 | Run button and indicator warning light |
| 4 | Stop button |
| 5 | Knead – extrusion selector switch |
| 6 | Pasta-cutter motor speed adjustment knob |

INDICATOR WARNING LIGHT INFO

- A. Slow flashing and machine stopped – POWER ON
- B. Fixed light – MACHINE IN MOTION KNEADING OR EXTRUSION OPERATING
- C. Fast flashing and machine kneading – SAFETY THRESHOLD TRIGGERED (the machine functioning in extrusion has encountered an anomalous force and the machine has reversed the function to kneading; check moisture of pasta or the outfeed extrusion).

3.4 ACCESSORIES SUPPLIED

4 dough plates (the type of plate is chosen by the customer when the order is placed).

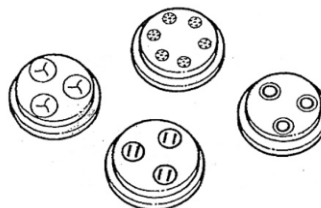

1 spanner for the plate supporting ring nut

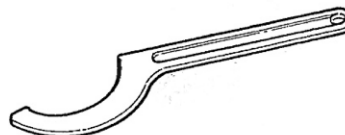

3.5 OPTIONAL ACCESSORIES

1 dough-cutter motor with the dough cutter motor (1 blade and 2 blades).

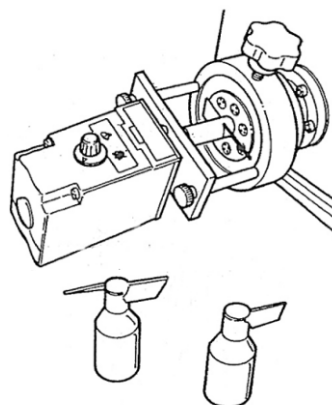

n° 1 cutter with 4 blades for the dough-cutter motor.

GENERAL INFORMATION	1
SAFETY	2
GENERAL DESCRIPTION	3
INSTALLATION	4
USE	5
MAINTENANCE	6
SPARE PARTS	7
SINGLE-PHASE WIRING DIAGRAM	8

DOLLY

IMPERIA & MONFERRINA S.p.A.

BLANK PAGE

4. GENERAL

Before installation of the machine:

- Remove the protective packaging;
- Remove any fastening restrictions used for transport.

4.1 INSTALLATION

4.1.1 Positioning



WARNING!

Before starting the positioning, carefully visually inspect the machine to identify any damage caused during transport.

If one or more components are found to be damaged, do not proceed with the installation and notify the manufacturing company of the fault found, agreeing with same on the action to be taken.

The machine will be able to operate according to the foreseen technical parameters providing it is correctly arranged on the workshop floor so that it is stable during operation.

When cleaning, the persons assigned to these operations are to be equipped with the necessary personal protection devices.



CAUTION!

Electrical connections are to be carried out by skilled experts who have been appropriately trained.

4.1.2 Installation



WARNING

All the operations described below are with the tank without the flour.

Position the machine on a perfectly level table.

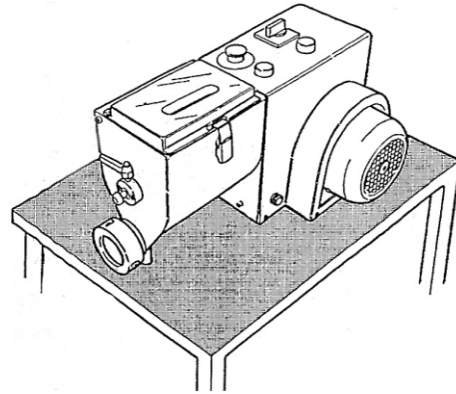

Unscrew the plate support ring nut (1).

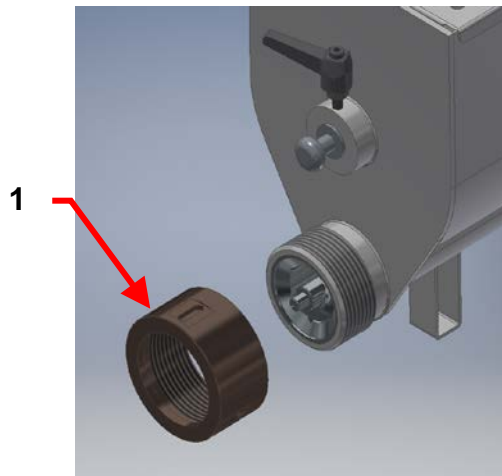

Make sure the sleeve is inserted correctly.



NO



YES

Insert the plate required into the ring nut and screw the ring nut with plate into the machine again.

If you wish to produce short pasta, choose the suitable dough-cutting blade from the three supplied.

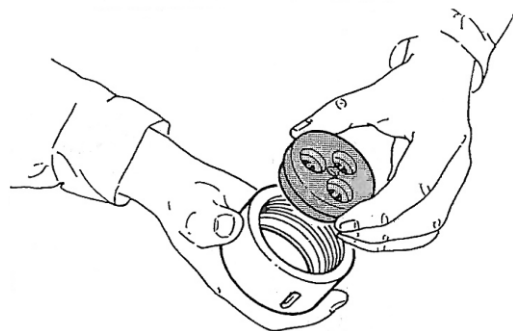

Insert the spring supplied into the blade and fit it onto the pin on the dough-cutter motor (optional).

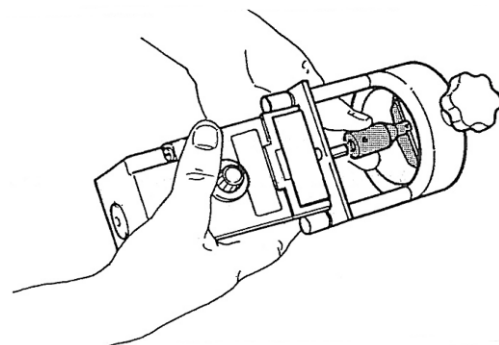

CAUTION!

Handle the dough-cutting blades carefully.

DOLLY

IMPERIA & MONFERRINA S.p.A.

Fit the dough-cutter motor onto the machine by fixing it with the knob shown in the figure.

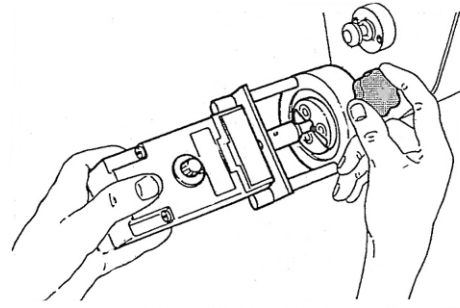

Insert the dough-cutter motor power supply jack into the socket (2) on the machine.

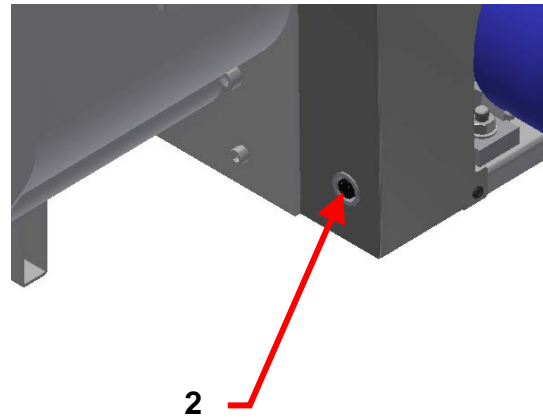

4.2 MACHINE ELECTRICAL CONNECTION

Check that the main switch is on position "0", connect the power supply cable to the machine and the electric plug to the mains socket.

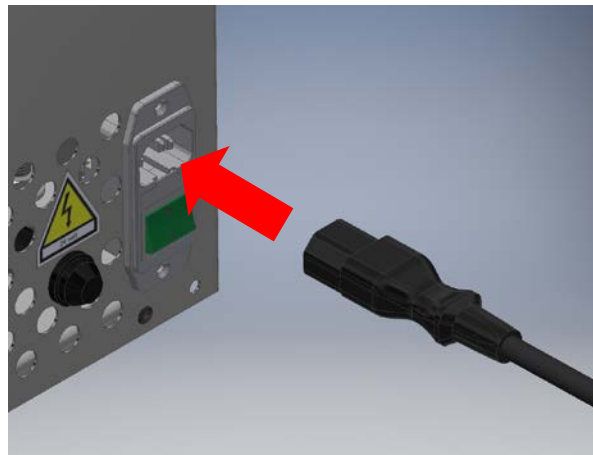

CAUTION!

Before starting the machine, make sure the voltage specified on the ID plate corresponds to the mains voltage.

Supply the machine setting the main switch (1) to "I".



Start up the machine by turning selector switch (5) to the left to the KNEAD position.

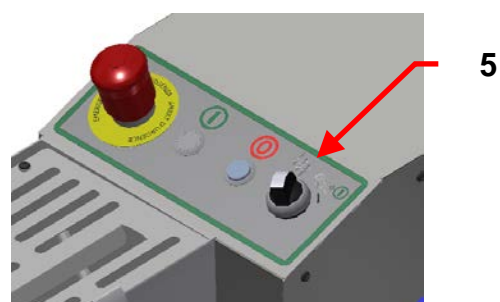

When "START" button (3) is pressed, the mixer shaft (that can be seen through the upper cover) must turn in an anticlockwise direction as shown in the figure.

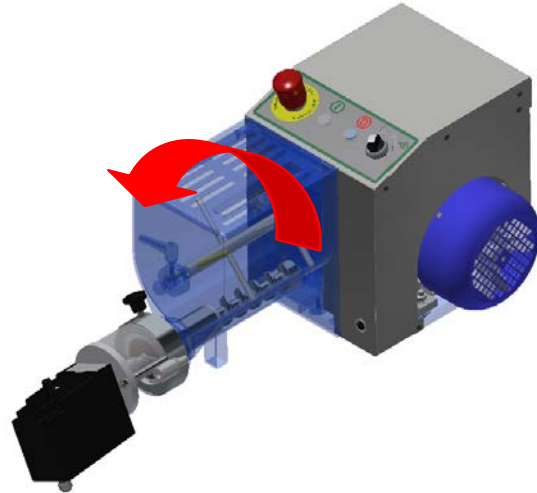
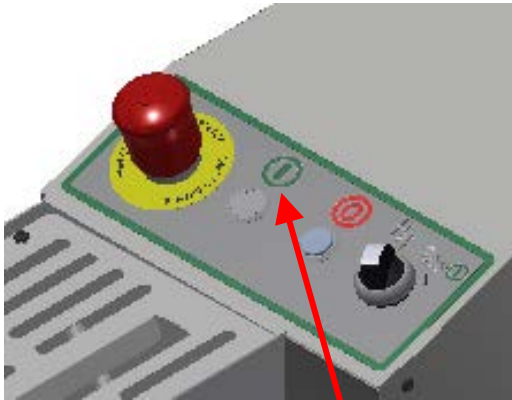

4.2.1 Safety microswitch check

Periodically check correct functioning of the safety microswitch: when the steel cover-tank is raised, the machine processing must stop

Safety microswitch

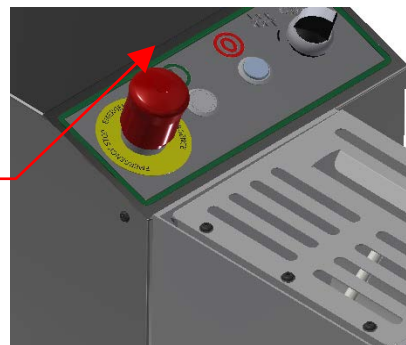

CAUTION!

If the machine does not stop when the cover-tank is opened, promptly contact the authorised technician for replacement of the safety microswitch

4.3 REMOVAL AND DISPOSAL OF PACKAGING

The machine packing consists of:

- Wooden box: usually deal-poplar, recyclable material.
- Protective sack: sack in recyclable aluminium.
- Expanding film: expanding polyethylene film. recyclable (LLDPE).
- "Bubble" film: polyethylene film or recyclable material.
- Cardboard: cardboard with air bubbles, recyclable.
- Polystyrene: non-recyclable material



WARNING

All packaging materials are to be disposed of in accordance with the standards in force regarding waste disposal and separated collection.

BLANK PAGE

GENERAL INFORMATION	1
SAFETY	2
GENERAL DESCRIPTION	3
INSTALLATION	4
USE	5
MAINTENANCE	6
SPARE PARTS	7
SINGLE-PHASE WIRING DIAGRAM	8

DOLLY

IMPERIA & MONFERRINA S.p.A.

BLANK PAGE

5. USE

5.1 WORK CYCLE

Before the cycle

- Check that the main switch (1) is set on "1".
- Make sure you have complied with all the precautions described in the Safety section.

Work cycle

- Open the cover and fill the mixing tank with the basic ingredients (flour and/or hard-grain durum flour), water and/or eggs.
- You are recommended always to weigh the flour and/or hard-grain durum flour poured into the tank to be able to determine the precise quantity of liquid (water and/or eggs) to be added.
- Break the eggs into a separate vessel thereby preventing any shell falling into the tank and clogging up the plate.
- You are also recommended to beat the eggs well so the yolks blend well with the whites.



WARNING!

Read the advice concerning pasta production contained in the chapter "Machine description"

Further details regarding electrical connections and the components used can be found on the wiring diagram and related bill of materials.



ADDITIONAL INFORMATION

With regard to functioning, specific programming functions, specific parameters and all possible applications of the control panel, see the relevant instructions for use manual attached to this manual.

Close the cover (a) and secure it with the relevant safety catch (b).

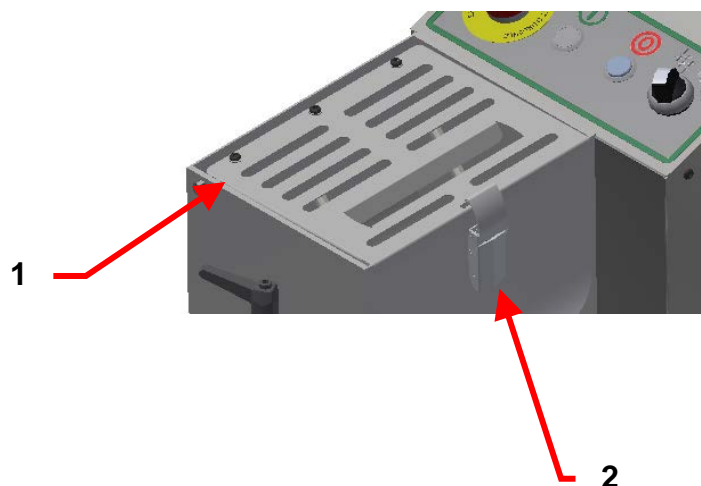



CAUTION!

Open the cover to rest against the tank; without entering over-travel; this operation could cause safety microswitch malfunctioning.

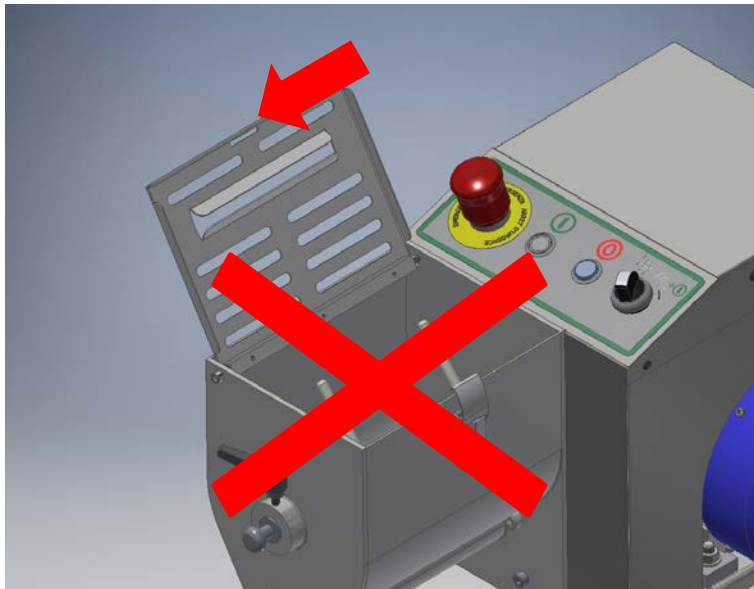

DANGER

Never remove the stainless-steel cover or tamper with the safety microswitch

- Turn the selector knob 5 to the left and position it on "KNEAD"
- Press the start button 3.
- Add the water and/or eggs.



WARNING!

Under no circumstances let the machine run with the selector switch 5 turned to the "EXTRUDE" position before kneading the flour. This could cause serious mechanical damage.



DANGER!

If, when the "run" pushbutton 3 is pressed, the white warning light 5 switches on, but the machine does not start and when the pushbutton is released the warning light switches off, this means that the motor thermal overload protection has triggered. Allow to cool before restarting.

- The friable dough broken up into granules will be ready to be extruded after around 15 minutes.



WARNING!

Do not wear loose garments or protruding elements that could get caught up in the machine.

To produce long pasta (tagliatelle, spaghetti, etc.):

- Turn the knob of selector switch 5 to the right from the previous “KNEAD” position  to

“EXTRUSION”  and hold it in position.

- Press button 3 “RUN” and release selector switch 5.
- Begin to cut the dough coming from the plate with a spatula or blade.

To produce short pasta

- - Stop the “KNEAD” function, pressing the STOP button “4”.
- Fit the dough-cutter motor, with a blade selected for the length of the cut, onto the plate and secure it by tightening the safety knob.

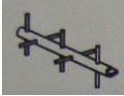
- Turn the selector knob 1 to the right to the previous “KNEAD”  position to the “EXTRUDE”

position .

- Press the button 3 “START”.
- Turn knob 6 to regulate the dough-cutter blade rotation speed.

5.2 CHANGING THE PLATE

To change the pasta type it is necessary to change the plate in the following way:

- Press the button 4 "STOP".
- Unscrew the knob and remove the dough-cutter motor

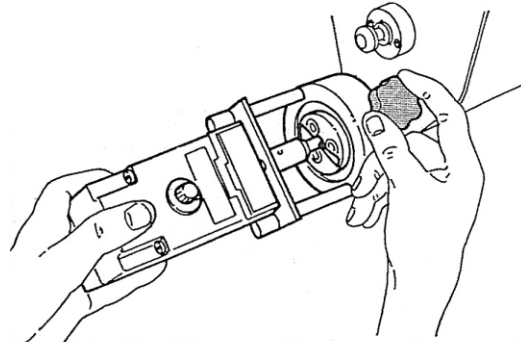

- Turn the selector knob 5 to the left, to the

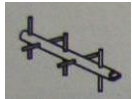

"KNEAD" position

- Press the button (3) "START" and let the machine run for some 10 seconds, reducing the pressure inside the plate.
- Stop the machine by pressing the button 4 "STOP".
- Bring the selector (5) to central position
- Cut-out the power supply turning the rear switch to "0"
- Loosen the ring nut with the special spanner supplied.

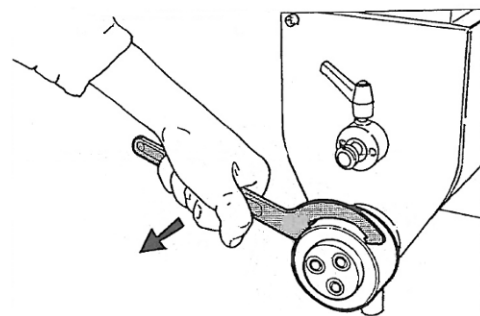
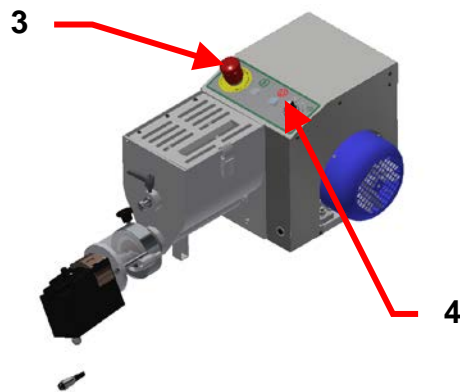

- Unscrew and remove the ring nut.

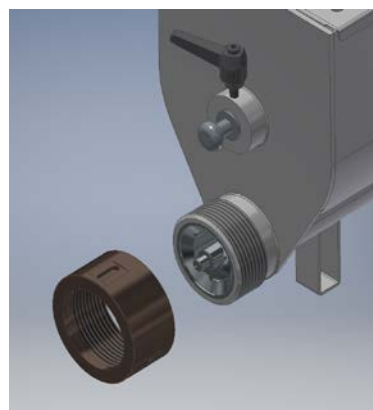

- Remove the plate and replace it with another.

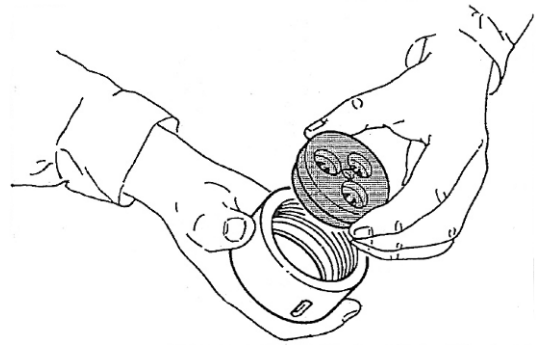

WARNING!

After use, the plates must always be immersed in a container full of water to prevent the dough from drying.

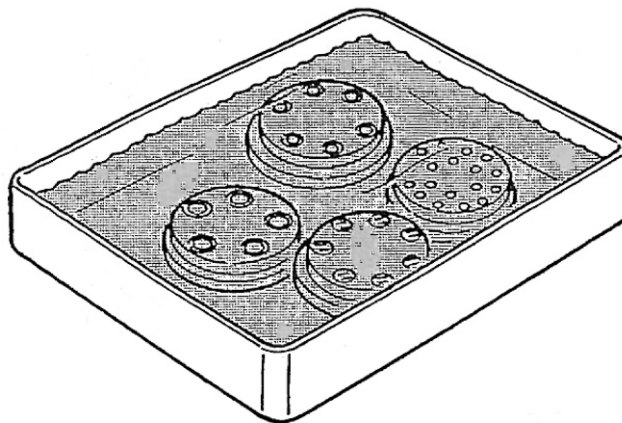

WARNING

All operations regarding disassembly and assembly of the extrusion are to be carried out with attention and following the checks and precautions described in the "INSTALLATION" paragraph.



WARNING

When refitting an extrusion device that has been previously immersed in a container with water, it is necessary to carry out the procedure described in the "WORK CYCLES" section. When starting the extrusion, place a sheet of paper in front of the extruder to collect and scrap the soggy pasta that comes out.

The normal processing cycle can be resumed as soon as the product coming from the extrusion is as required.

BLANK PAGE

GENERAL INFORMATION	1
SAFETY	2
GENERAL DESCRIPTION	3
INSTALLATION	4
USE	5
MAINTENANCE	6
SPARE PARTS	7
SINGLE-PHASE WIRING DIAGRAM	8

DOLLY

IMPERIA & MONFERRINA S.p.A.

BLANK PAGE

6. MAINTENANCE

6.1 GENERAL SAFETY PRECAUTIONS

Operations concerning maintenance, troubleshooting and repairs are only to be carried out by the authorised persons.

The persons who run and carry out maintenance on the machine are to be well trained and have in-depth knowledge of accident-prevention rules; unauthorised persons are to remain outside the work area during operations.

The accident-prevention precautions contained in this section are to be scrupulously followed when running and carrying out maintenance on the system to avoid damage to persons and to the equipment.

These precautions will also be found in the handbook with further details, in **WARNING** and **DANGER** notes where there is a procedure required having a risk of damage or injury:



DANGER notes precede an operation that, if not performed correctly, could cause an accident. These notes, to be borne in mind during maintenance operations, indicate a hazard with risk of serious injuries for the person.



WARNING notes precede an operation that, if not performed correctly, could cause damage to the equipment.

At the end of every maintenance operation, it is obligatory to restore the protections and check correct functioning.

6.1.1 General Hazard Notes

- High voltages can cause death upon contact. Always work with maximum caution and in accordance with the accident prevention rules in force in the country.
- When the machine is running there are moving parts that can cause serious damage to persons. For this reason cleaning and special maintenance operations that require removal or replacement of components on the machine or control units, are to be carried out with the system off and with no pressure in the systems:
 - Main switches are to be in OFF position (OPEN) and locked with a safety padlock that prevents being turned to On position;
- Place specific SYSTEM BEING SERVICED - DO NOT POWER ON warning signs on the main switches and air reduction and filtering unit.
- Do not use inflammable or toxic solvents.
- Always wear goggles and protective gloves when carrying out maintenance operations on the equipment.
- Make sure tools to be used are in perfect condition and with isolating grips, where required. Check that insulation of cables and conductors of testing equipment have no signs of breakage or damage.
- Long overloads or failures can cause overheating of electric motors and electrical equipment generating harmful fumes; cut out the power supply immediately and do not approach the equipment until the fumes have been dispersed with adequate ventilation. Do not inhale the fumes remaining inside the equipment during the repair jobs.
- In the case of fire, never spray water on the equipment. Cut out all power supplies and use CO2 extinguishers.
- Avoid prolonged, excessive or repeated contact of the skin with lubrication products and change clothes immediately if they become impregnated, because lubricants are very harmful for the skin.
- Before making the connections carefully inspect all the fittings and make sure they are free of dirt or defects on the threads.
- Maintenance operations, repairs and troubleshooting are to be concluded with a careful check on correct machine operation and restoration of all the safety devices.

6.1.2 General Warnings

- Machine maximum reliability and minimum maintenance costs are the result of a maintenance and inspection schedule planned and scrupulously followed during the entire system life. Scrupulously observe the maintenance time scales set and time operations according to specific requirements related to the machine production cycle.
- If operations of a certain consistency are necessary, it is advised to contact the Manufacturer for any clarifications regarding the project or technical assistance.
- Before starting checking and maintenance operations, remove dirt from the system.
- Always use perfectly dry air for cleaning, with a pressure that does not exceed 0.2 MPa.
- Always use tools in perfect working order and specifically for the operation to be carried out; use of inappropriate and/or inefficient equipment can cause serious damage.
- Repair operations are to be carried out in clean environments, and where possible without dust. Protect all connection gaps with plastic plugs and carefully cover machined surfaces of dismantled parts, until they are refitted on the machine.
- During disassembly, mark the individual parts with an identification plate, to make sure that they are assembled correctly later.
- After every maintenance operation that requires disconnection of wiring and/or fixed and mobile parts, check the consistency of the number/plate on fixed and mobile part.
- Before restarting the equipment after a failure, inspect the parts carefully and check for any signs of damage.
- Never act, unless there has been a failure, on adjustments and positions of microswitches; tampering with them can cause serious damage to the machine.

6.2 QUALIFICATION OF MAINTENANCE TECHNICIANS



WARNING

The safety warden shall make sure that all the persons operating on the machine have received all the instructions that concern them, contained in this handbook, including the initial installation and start-up operations.

6.2.1 General Tasks

To attain the qualification requirements that continually increase in maintenance for fully automated manufacturing systems, the maintenance technicians shall:

- have knowledge of directives in force regarding prevention of accidents when working on machine with motor transmission, and be able to apply them,
- have read and understood the "Safeties applied to the machine",
- know the fundamental construction and functions of the manufacturing system for special workpieces,
- know how to use and consult manufacturing papers and machine documents,
- assume the responsibility to make decisions regarding operations on fully automated manufacturing systems,
- be ready to adapt to technological modifications on the machine,
- note irregularities in the production process and when necessary take the necessary measures.

6.2.2 Tasks of Qualified Operators

The composition and qualifications of the teams indicated in the maintenance plan are those recommended by the Manufacturer

The operations, if necessary can also be carried out by persons with the same or higher qualifications, who have attended the relevant training courses.

6.2.2.1 Machine manager

Typical activities:

Control and maintenance of production quality on fully automated manufacturing systems, and in particular:

- mechanical clearances on guides and kinematic chains adjustment;
- driving belts replacement;
- execution of movements check;
- mechanical clearances on shoes and rollers check;
- mechanical unit repairs.

Technical knowledge required:

- good knowledge of mechanical, pneumatic and hydraulic installations;
- familiarity with numeric controls used on the machine;
- basic knowledge of electrical adjustment and checking techniques;
- ability to assess results of overhauls and decide the measures to be taken;
- know how to draw up an overhaul report;
- knowledge of measuring and test methods to determine the actual state of the machine/movement.

Qualification required:

- Complete training as industrial mechanic with specialisation in technical sector of automated systems;
- Experience in maintenance of automatic handling systems. Instruction and training on the machine are assured by the manufacturer.

6.3 SAFETY CONTROL PLAN



WARNING

It is strictly forbidden to electrically or mechanically jumper safety switches of guards, light barriers, safety circuits or tamper with them in any way.

6.3.1 Checks and Functional Tests on Safety Devices

Maintenance technicians have the obligation to periodically check functioning of safety devices.

The operation is to be carried out by competent persons with specific knowledge on the uses of safety devices.

This procedure is to be repeated as a routine maintenance operation.

EMERGENCY PUSHBUTTONS

Check efficiency of the emergency buttons located on the machine: Press one and check that both output channels on the safety relay have triggered (shown by indication LED).

Repeat the operation for all the emergency buttons on the machine.

6.4 STOP PROCEDURE FOR MAINTENANCE

Before carrying out the maintenance procedures the operator has to stop the machine and set it in maintenance mode, using this procedure:

- Arrange the machine in the best conditions to be able to resume operation without delays caused by anomalous cycle conditions
- Check for residual energy, and if necessary discharge it before operating on the device.
- Cut out machine power supplies if this is required by the maintenance operations. Otherwise it is not necessary. The cards indicate electric power and fluidic supply OFF or otherwise electric power and fluidics ON.
- Place the "MACHINING CENTRE BEING SERVICED – DO NOT POWER ON - WORK IN PROGRESS, DO NOT PUT IN MOTION" warning sign near the main switches
- Carry out the maintenance operations described on the relevant cards.
- After the maintenance operations restore the power supplies.
- Before resuming machine normal functioning, check again the whole machine, applying the start-up procedures.
- After every maintenance operation, check correct machine functioning during a few working cycles.

6.5 CLEANING AND MAINTENANCE



CAUTION!

Before starting any type of maintenance work, cut out and lock all energy sources and block the machine safeties. Place a warning signboard near the main switch. "MACHINE BEING SERVICED DO NOT POWER ON".

Before putting back into service, recheck the entire system according to the start-up procedures. Ignoring these precautions could cause serious injuries for the personnel!

To make it easier to clean inside the mixing tank, the shaft should be removed in the following way:

- Remove the kneading shaft (1) from above after taking out the clamping pin (2) loosening the lever (3) and turning it clockwise.
- Clean with a moist sponge.

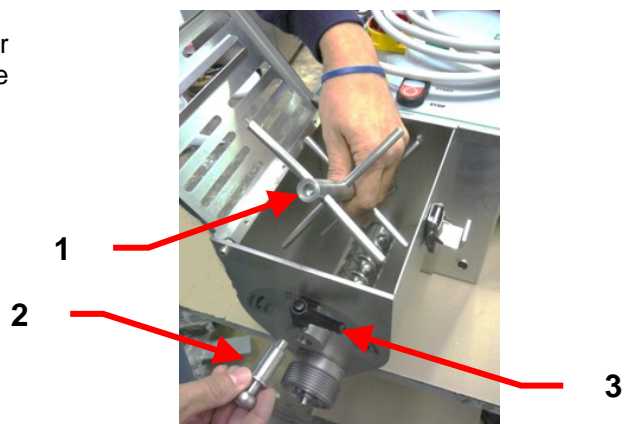

- Remove the ring-nut that holds the extruder (4) with the appropriate spanner (5).



- Remove the extruder (6).
- Detach the extruder from the ring nut and immerse it in a container full of water. The residual dough inside the extruder holes must never be allowed to dry.

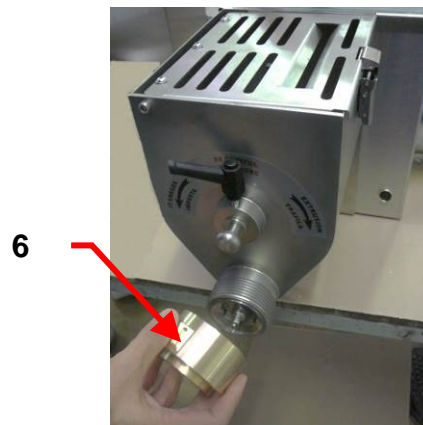

- Remove the screw (7) from inside the tank and clean it with a moist sponge.



- Tighten the ring nut (4) by hand to clamp the extruder in its housing at the end of stroke.



- Insert part (8) of the ejector outwards from inside the tank.



- Insert part (9) of the ejector into part (10).



- Using the spanner (5) supplied with the machine, unscrew the ring nut that clamps the extruder (4) turning it anticlockwise until the notched sleeve (11) comes out completely.
- Clean the notched sleeve and inside the tank with a moist sponge.
- Refit the kneading shaft.





WARNING!

Do not use jets of water to clean the machine. Never fit a plate left out of the water



CAUTION!

After cleaning make sure the sleeve is inserted correctly!



NO



YES

- Refit the screw and the extruder holder ring-nut.

BLANK PAGE

GENERAL INFORMATION	1
SAFETY	2
GENERAL DESCRIPTION	3
INSTALLATION	4
USE	5
MAINTENANCE	6
SPARE PARTS	7
SINGLE-PHASE WIRING DIAGRAM	8

DOLLY

IMPERIA & MONFERRINA S.p.A.

BLANK PAGE

7. SPARE PARTS

7.1 COMPONENTS SUBJECT TO WEAR AND MECHANICAL FATIGUE



CAUTION!

The components subject to wear caused by the relevant functioning are to be checked at regular intervals and replaced as soon as they show significant signs of wear

The manufacturer has designed and built the machine for a rational life, taking into account the normal use conditions of the Customer; in any case all these components have to be meticulously checked periodically.

Should “mechanical cracking” or permanent or cyclic structural deformation be found, immediately contact the Manufacturer and expert technicians who will take the necessary action.

Electrical wires, especially if exposed to heat, humidity and/or low temperatures lose their insulating characteristics over time.

With the aid of skilled technicians, check the integrity.

All electrical components with mechanical parts in motion during the work cycle (pushbuttons, selector switches, relays, etc.) are guaranteed by the manufacturer for a certain number of cycles, high, but still limited.

Check their condition frequently and contact skilled technicians for any periodical replacement within the guaranteed working life indicated.



ENVIRONMENT!

Removed parts that have been replaced are to be delivered to the specific collection centres for disposal.

7.2 LIST OF RECOMMENDED SPARE PARTS

The recommended spare parts are not incorporated in the supply of the machinery, unless provided for in the initial purchasing contract.

7.2.1 Table 1

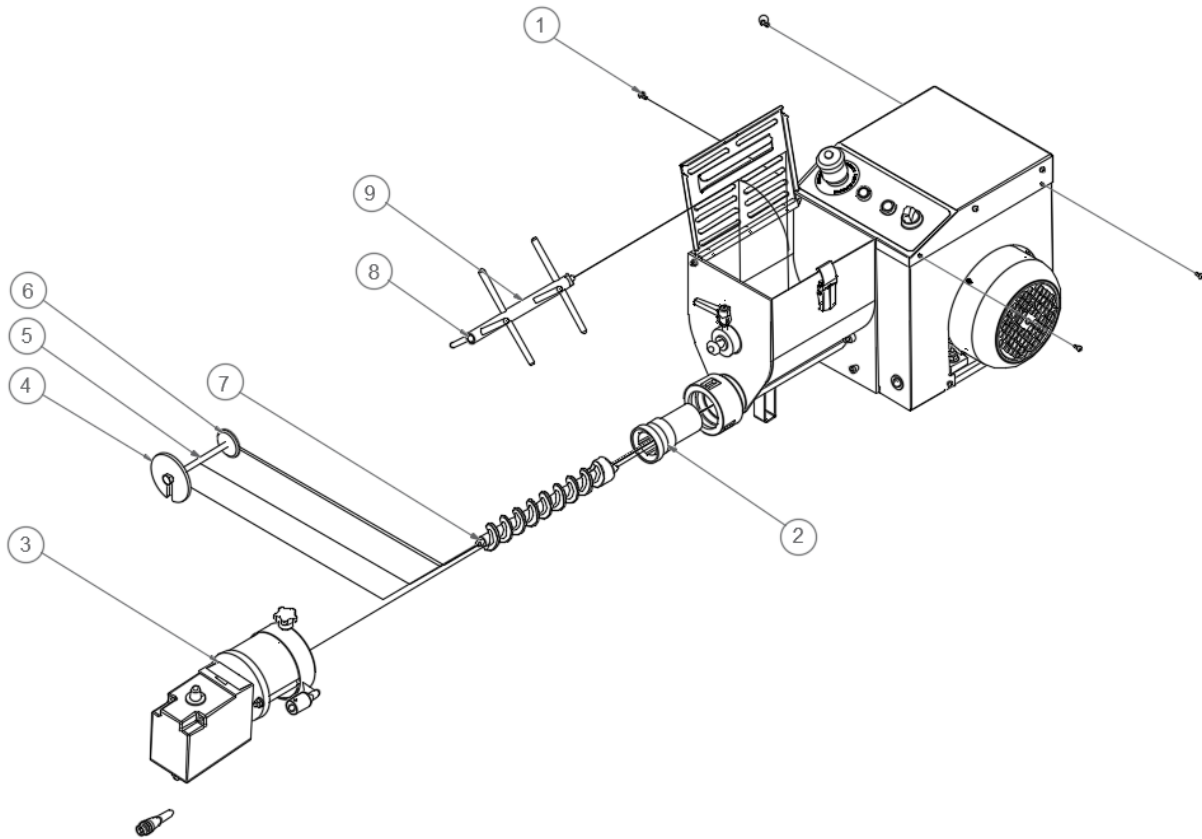

Item	Code	Description	Qty
1	LM-1302	ISO 7380 – Button head socket screw M4x8	4
2	LM-2818/2	Scored sleeve for extrusion D=59	1
3	LM90920	Dough-utter for Dolly	1
4	LM-14136	Open washer	1
5	LM-14138	UNI 5737 – Hex head screw M8x120	1
6	LM-14137	Threaded washer	
7	LM-2817	Screw	1
8	LM-2825	Bushing for kneading shaft	1
9	LM-2826	Complete kneading shaft	1

7.2.2 Table 2

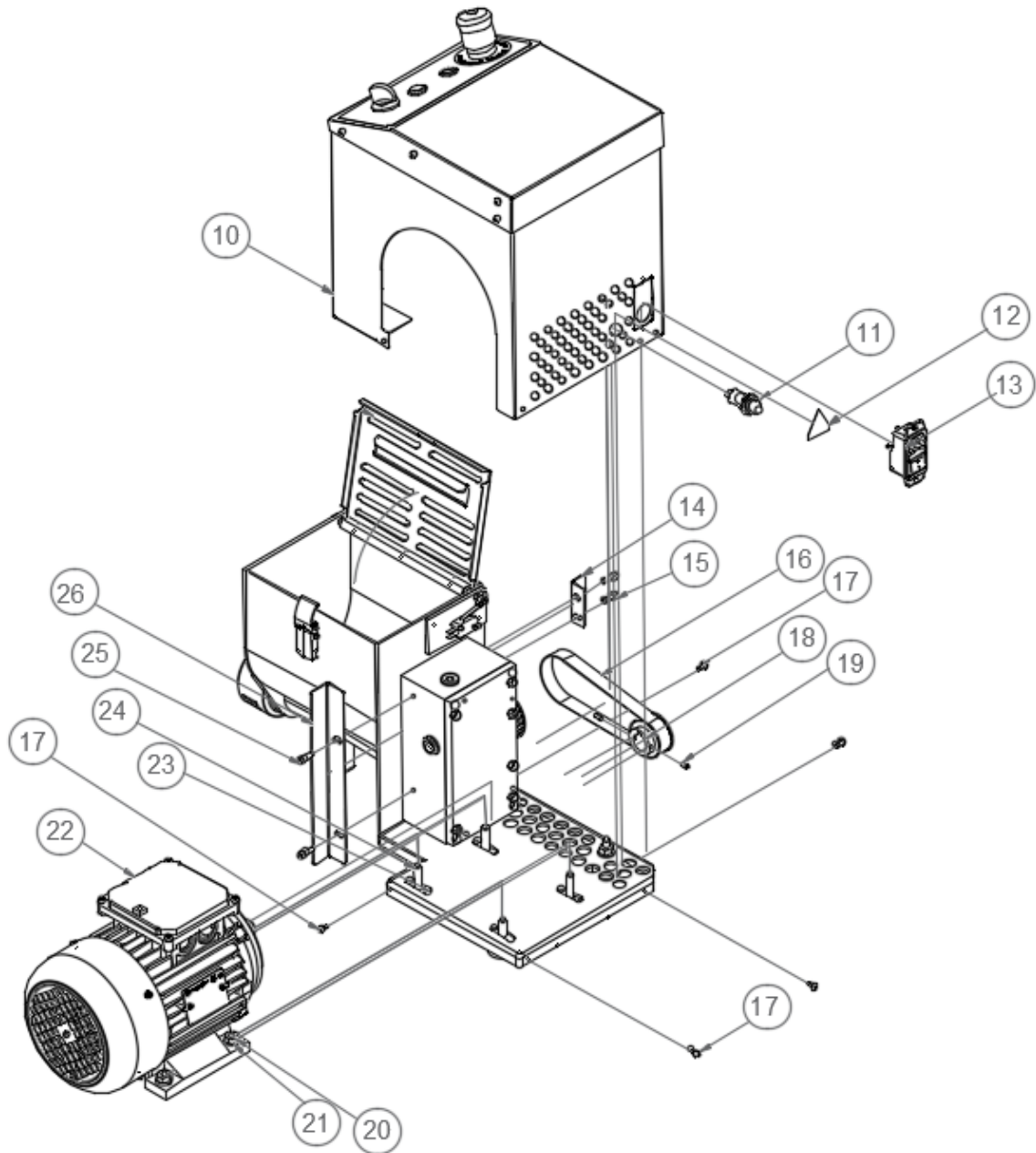

Item	Code	Description	Qty
10	LM-14118	Stainless steel casing with slot for connector AISI 304	1
11	LM-859	Single fuse-holder	1
12	LM-73708	Adhesive label 24V yellow triangle 11810010 AW	1
13	LM-62516	Connector IEC 320 C14 with fuse and switch	1
14	LM-2804	Casing retaining bracket	1
15	LM-277	UNI 5931 – M 5 x 12 – Cheese-head screw	4
16	LM-2833A	Synchronous belt	1
17	LM-1302	Button head socket screw M4x8	4
18	LM-2827BF	Driving pulley for motors 60 Hz	1
19	LM-3362	UNI 5923 – Hex countersunk head screw M5x8 (for 50 Hz)	2
20	LM-1660	UNI 5588 – Hex nut M8	4
21	LM-2676/2	UNI 6592 - Washer 8,4x17	4
22	LM-71160	Electric motor M80 B14 TF 230/400V 50/60Hz	1
23	LM-1215	UNI 6593 - Washer 9x24	3
24	LM-1661	UNI 5931 – Cheese-head screw M8x30	3
25	LM - 2844	Casing retaining bracket	1
26	LM-14120	Dolly base group	1

7.2.3 Table 3

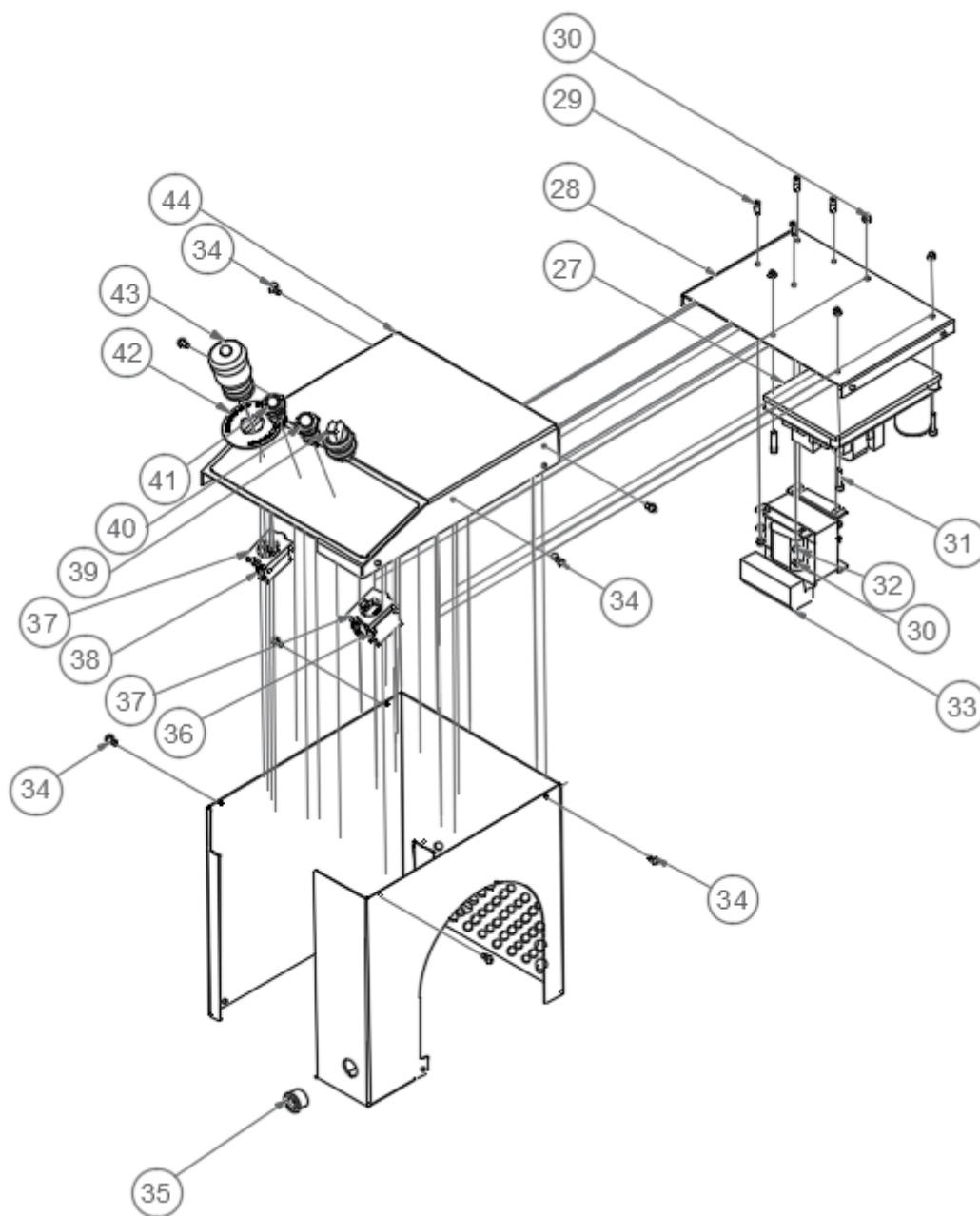

Item	Code	Description	Qty
27	LM-62535	Inverter board 0.75Kw with button connectors	1
27	LM-62515	Inverter 2.2Kw board with button connectors	1
28	LM-14114	System support plate	1
29	LM-953	Cheese-head screw	4
30	LM-1737	Self-locking hex nut	4
31	LM-1662	Cheese-head screw	4
32	LM-999	Washer	4
33	LM-2851/1	Transformer 30VA 110-24V TM30	1
33	LM-2851	Transformer 30VA 230-24V TM30	1
34	LM-1302	Button head socket screw	8
35	LM-2852	Panel 3-pole socket	1
36	LM-62272	Normally open contact	1
37	LM-68566	Adapter to fasten connector inserts	2
38	LM-62275	Normally closed contact	1
39	LM-68076	Two-position selector switch	1
40	LM-62513	Protruding pushbutton in stainless steel 19	
41	LM-62514	White luminous button in stainless steel 19	1
42	LM-62276	Emergency button label	1
43	LM-68012	Emergency button	1
44	LM-14113	Cover with inclined plane	1

7.2.4 Table 4

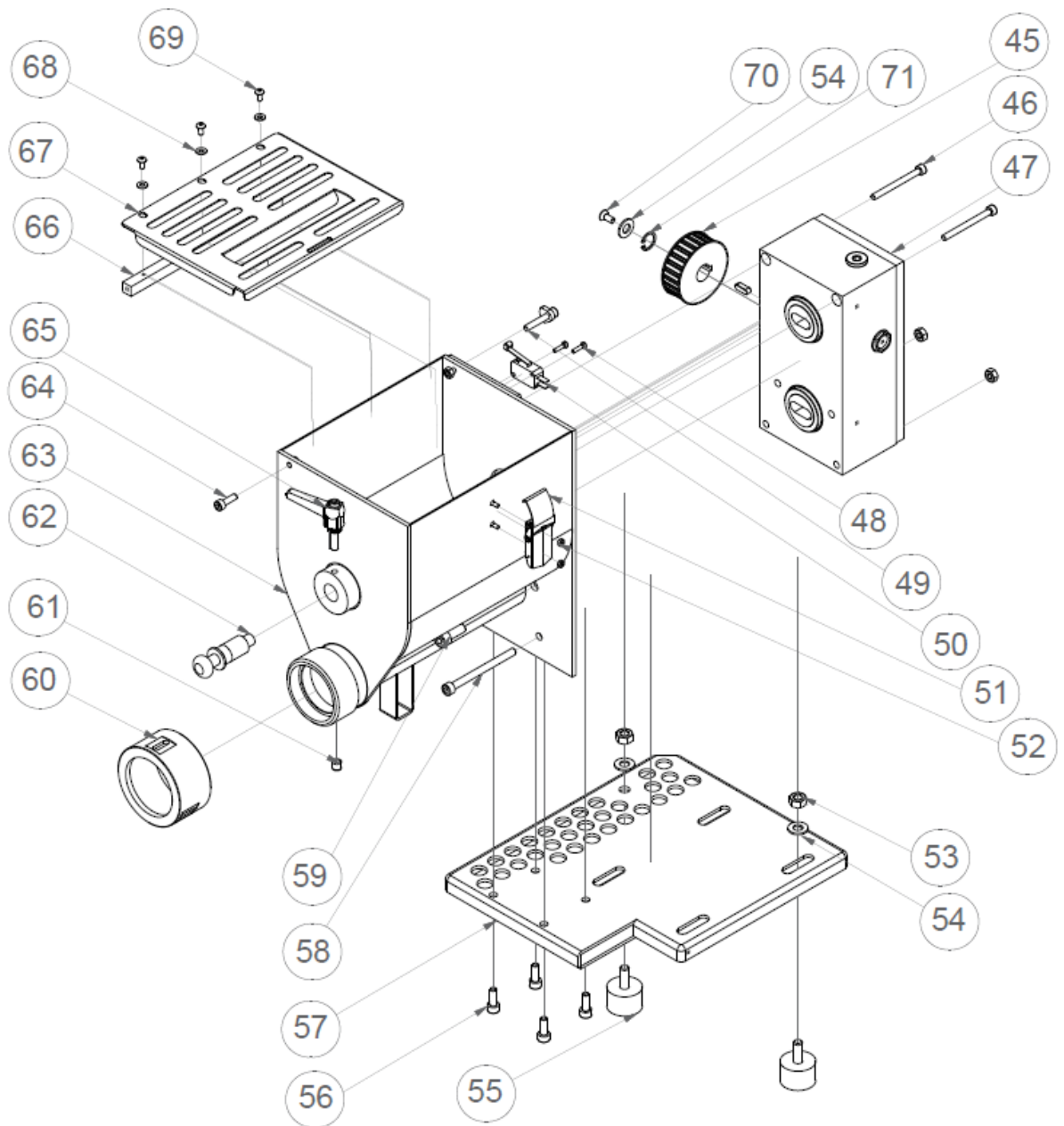

Item	Code	Description	Qty
45	LM-2805AF	Driven pulley	1
46	LM-71800	Cheese-head screw	2
47	LM-14146	New reduction unit assembly	1
48	LM-1190	Slotted cheese head screw	2
49	LM-14109	Welded cam	1
50	LM-2840	Long lever microswitch Omron V156-1C5	1
51	LM-1506	Hooking unit	1
52	LM-1112	Hex nut	2
53	LM-1660	Hex nut	2
54	LM-1512	Washer	3
55	LM-1639	Rubber foot 30 H 20 M8 x 23	2
56	LM-901	Cheese-head screw	4
57	LM-2830F	Finished base	1
58	LM-2835	Cheese-head screw	2
59	LM-1603A	Cheese-head screw	2
60	LM-2819	Extrusion clamping ring nut	1
61	LM-1749/5	Hex countersunk head screw	1
62	LM-2824	Pin for kneading shaft	1
63	LM-14149	Kneading tank with plate	1
64	LM-842	Cheese-head screw	1
65	LM-74289	Locking handle	1
66	LM-2829	Tank cover hinge	1
67	LM-14112	Stainless steel cover	1
68	LM-489	Washer	3
69	LM-1302	Button head socket screw	3
70	LM-1162	Flathead screw	1
71	LM-219	Stop circlip	1

7.2.5 Table 5

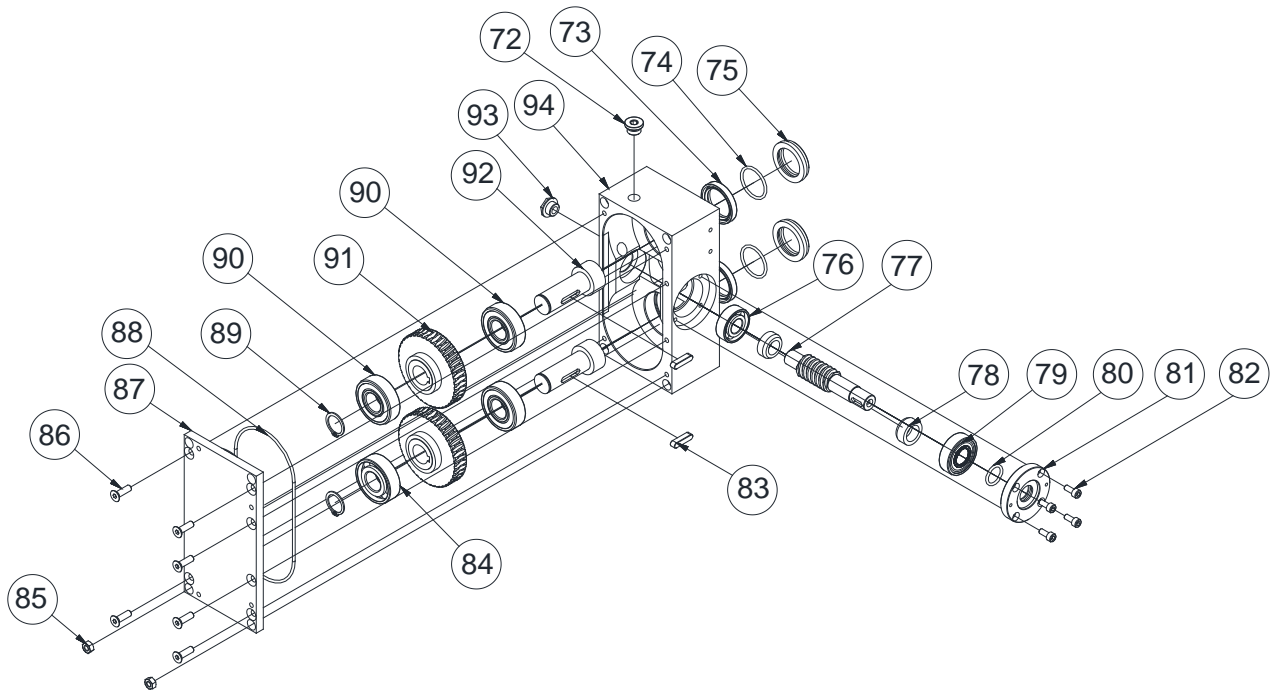

Item	Code	Description	Qty
72	LM-3369	Male socket head cap	1
73	LM-2811	Precision seal	2
74	LM-293	O-Ring	2
75	LM-2812	Ring for OR	2
76	LM-1422	Angular contact ball bearing 15/35/11	1
77	LM-2807	Worm screw M1.75 - 2 princ. - elic.	1
78	LM-2806	Spacer for worm screw	1
79	LM-2539	Radial ball bearing 17/40/12	1
80	LM-10147	O-Ring	1
81	LM-14147	Flange for worm screw with O-Ring	1
82	LM-277	UNI 5931 – Cheese-head screw M5x12	4
83	LM-1217	UNI 6604 –Parallel key A6x6x25	2
84	LM-2813	Single row angular contact ball bearing	1
85	LM-1186	UNI 5588 – Hex nut M6	2
86	LM-1162	UNI 5933 – Flathead screw M5x12	1
87	LM-14144	Reduction unit cover	1
88	LM-10146	O-Ring	1
89	LM-2032	UNI 7435 – Stop circlip ø20	2
90	LM-1413	Single row radial ball bearing	3
91	LM-2809	Cogged wheel	2
92	LM-2810	Reduction unit shaft	1
93	LM-3368	Oil inspection window ¼ Gas TLT	1
94	LM-14143	Reduction unit housing	1

7.2.6 LM90920 dough-cutter motor

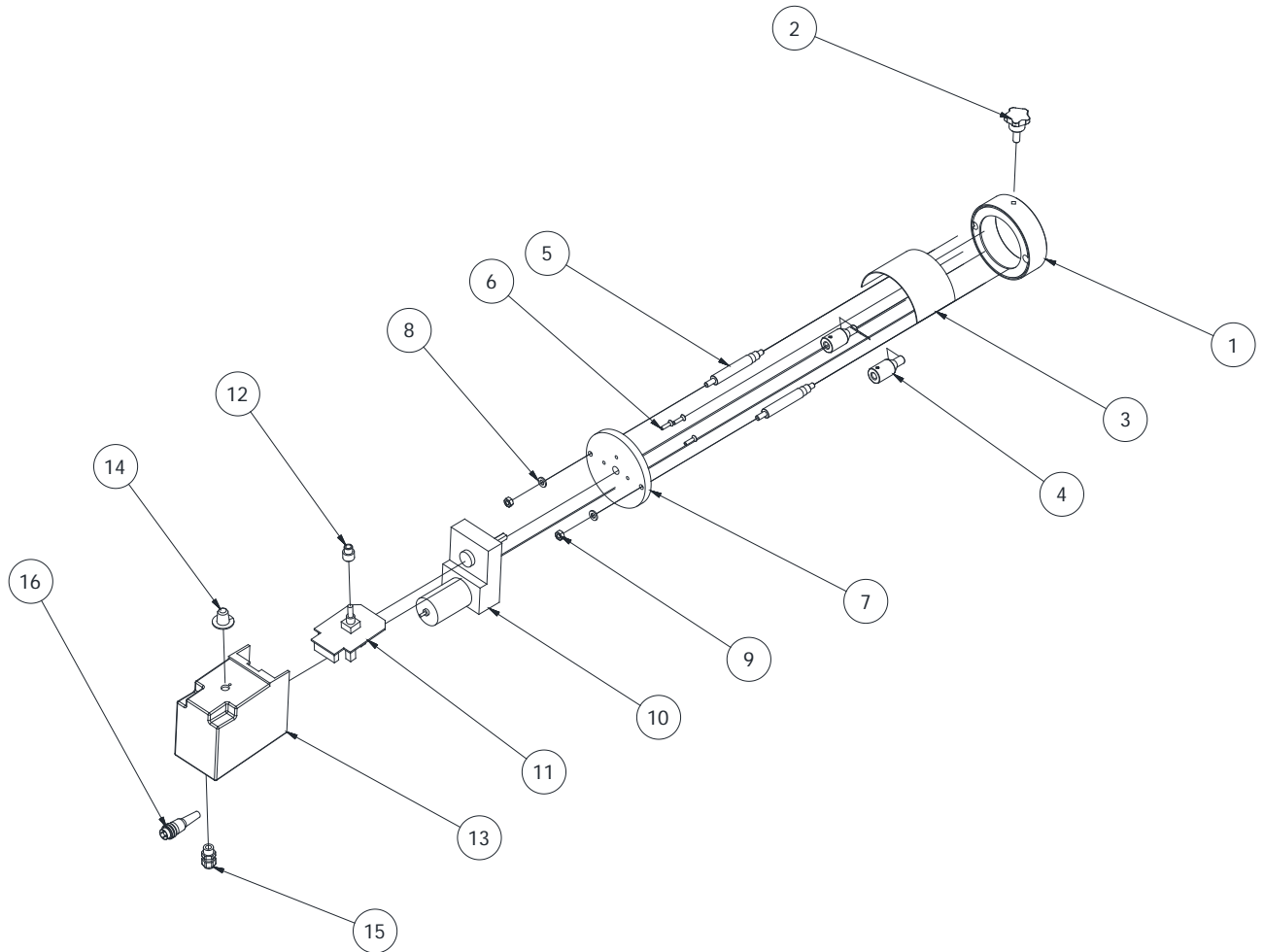

Item	Code	Description	Qty
1	LM-2820	Dough-cutter motor support ring	1
2	LM-2839/1	Lobed hand-wheel	1
3	LM-2856	Dough-cutter protection	1
4	LM-2821/A	Dough-cutter knife – one blade – clockwise cutter	1
4	LM-2821/B	Dough-cutter knife – two blades – clockwise cutter	1
5	LM-479	Dough-cutter motor pillar	2
6	LM-272	UNI 5933 – Flathead screw M4x14	3
7	LM-2822	Dough-cutter motor cross member	1
8	LM-495	UNI 6592 - Washer 6.4 x 12,5	2
9	LM-1715	UNI 5588 - Hex nut M6	2
10	LM-474	Electric motor	1
11	LM-992	Electronic board	1
12	LM-890	Dough-cutter motor bushing	1
13	LM-14103	Dough-cutter motor hood	1
14	LM-993A	Potentiometer knob	1
15	LM-930	Cable clamp PG 7	1
16	LM-2853	3-pole loose plug	1

GENERAL INFORMATION	1
SAFETY	2
GENERAL DESCRIPTION	3
INSTALLATION	4
USE	5
MAINTENANCE	6
SPARE PARTS	7
SINGLE-PHASE WIRING DIAGRAM	8

DOLLY

IMPERIA & MONFERRINA S.p.A.

8. SINGLE-PHASE WIRING DIAGRAM 220-240V E 110-120V

